



UPPER BIG BLUE Natural Resources District

319 East 25th Street
York, Nebraska 68467

402-362-6601
Fax: 402-362-1849
www.upperbigblue.org

Approved Flow Meter List April 2026

Water meters are critical in implementing accurate future water usage reporting and possibly allocation. In order to ensure accuracy, UBBNRD follows manufacturers' minimum installation requirements for specific brands of meters. These requirements are outlined in the following pages of this packet. **The following are some guidelines that can simplify the installation process and ensure you an accurate and useful meter:**

Minimum distances: If your current plumbing setup has MORE straight run distance than the minimum required, use that extra distance to install the meter **as far away as possible** from disturbances (particularly upstream disturbances) to ensure optimum accuracy. Remember, many requirements you will find in this packet are minimum, not optimum.

Types of Disturbances: Different flow altering devices (valves, etc) and fittings (elbows) create differing flow conditions. Valves typically produce a jetting flow condition, while fittings such as elbows create a non-jetting flow condition. Also, consider pipe size alterations such as reducers or increasers to exhibit non-jetting and jetting flow conditions, respectively. Most meters have different minimum installation requirements for each type of flow condition, and therefore, you will need to understand what flow conditions will exist in your installation. If you do not plan to install the meter yourself, be ABSOLUTELY SURE that your meter installer is familiar with installation requirements for your particular meter and plumbing situation.

Choosing the right meter: If you purchase a propeller type meter it is important that you have it calibrated to the correct inside pipe diameter. As a velocity-sensing device, the principle behind a flow meter is calculating flow volume by using the relationship between inside pipe diameter and flow velocity. An accurate flow volume is calculated by correctly calibrating the meter to the inside diameter of the pipe it is installed in. Also, for irrigation systems, you must purchase a meter model that totalizes in **acre-inches** (the rate of flow needle will still read GPM flow). This meter will be much more convenient (requiring less calculation) to read for reporting and irrigation management purposes. If applicable (depending on the type of meter) it must contain an **anti-reverse feature**.

Maintenance: Refer to the owner's manual that comes with your meter and follow maintenance recommendations. Particularly for propeller meters, periodic maintenance is critical to meter life. Keeping a meter in good condition will result in reliable readings that can be used both for reporting purposes and for checking and maintaining an efficient irrigation system. Electronic flow meters also require some maintenance. Batteries must be replaced on a regular schedule to reduce the risk of losing data during the irrigation season. **It is important to check to see if the meter is working each time you start and stop the irrigation system.**

Sincerely,

Terry Julesgard
Water Department Manager
UBBNRD

UPPER BIG BLUE NATURAL RESOURCES DISTRICT

Approved Flow Meter List

April 2026

The following flow meters are approved for use to record groundwater withdrawals required by the District's Groundwater Management Area Rules and Regulations. An approved flow meter must be installed when it is required by the District's Ground Water Management Area Rules and Regulations or when the District is providing cost-share assistance for the flow meter.

Meters approved for ALL groundwater measurement applications

McCrometer Propeller Flow meters (All models)
McCrometer McMag3000 Electromagnetic Flow Meter
McCrometer Dura Mag Electromagnetic Flow Meter
Geyser Flow Meter (All models)
ARAD WST - PERCISION – Woltman Silver Water Meter
ARAD IRT - Irrigation Water Meter
ARAD High Pressure Hydrometer Globe Type (BM)
ARAD High Pressure Hydrometer Angle Type (BMA)
ARAD Octave Ultrasonic
Senninger Flo-Wise Ag Rotor Meter
Senninger Flo-Wise Magmeter
SeaMetrics – AG1000/2000-Series Irrigation Magmeter
SeaMetrics – AG3000 & Valley 3000 Magmeter
SeaMetrics – AG90 Insertion Flow Meter
SeaMetrics – WMP104 Plastic Bodied Magmeter (2" & 3" models only)
Growsmart by Lindsay – IM3000 Magnetic Flow Meter
Sparling BlueWater Electromagnetic Flow Meter
Sparling FM31/FT194 Low Pressure Bolt-on Propeller Flow Meter
Bermad – M10 Electromagnetic Sensor Flow Meter
Bermad – MUT2300/MC406 Electromagnetic Flow Meter

Meters approved for non-irrigation applications only*

Hays Turbine Meter – WP Series
Master Meter – Multi-Jet Water Meters (5.8" thru 2" sizes)
GPI Commercial Grade Meters – A100, A200 and N100
Neptune High Performance Turbine Meter
Elster AMCO Water evoQ4 Electromagnetic water meter

* Use associated with an irrigation system will be considered on a case by case basis

UPPER BIG BLUE NATURAL RESOURCES DISTRICT

Approved Flow Meter List

April 2026

The following meters are approved for ***ALL*** groundwater measurement applications

McCrometer Propeller Flow Meters (all models)

Minimum Installation Requirements:

Flowmeters are velocity sensing devices and are vulnerable to certain upstream disturbances. Because of this, meters need certain lengths of straight pipe runs before and after the meter. These distances usually relate to the diameter of the pipe used. Obstructions can include elbows, valves, pumps, and changes in pipe diameter. The uneven flow created by these obstructions can vary with each system. If your application provides for more than five diameters of upstream run, use the available distance.

- **Minimum Upstream Requirement:** Mc Propeller meters should be installed **a minimum of five to ten times the diameter of the pipe downstream of any obstructions. See the diagram and corresponding tables below.** The exact upstream straight-pipe requirement is specific to the meter model number.
- **Minimum Downstream Requirement:** Mc Propeller meters should be installed **a minimum of one to two times the diameter of the pipe upstream of any obstructions.**

For upstream and downstream piping requirements relating to your specific meter, contact your local McCrometer representative. (Please be prepared to provide the serial number of your meter.)

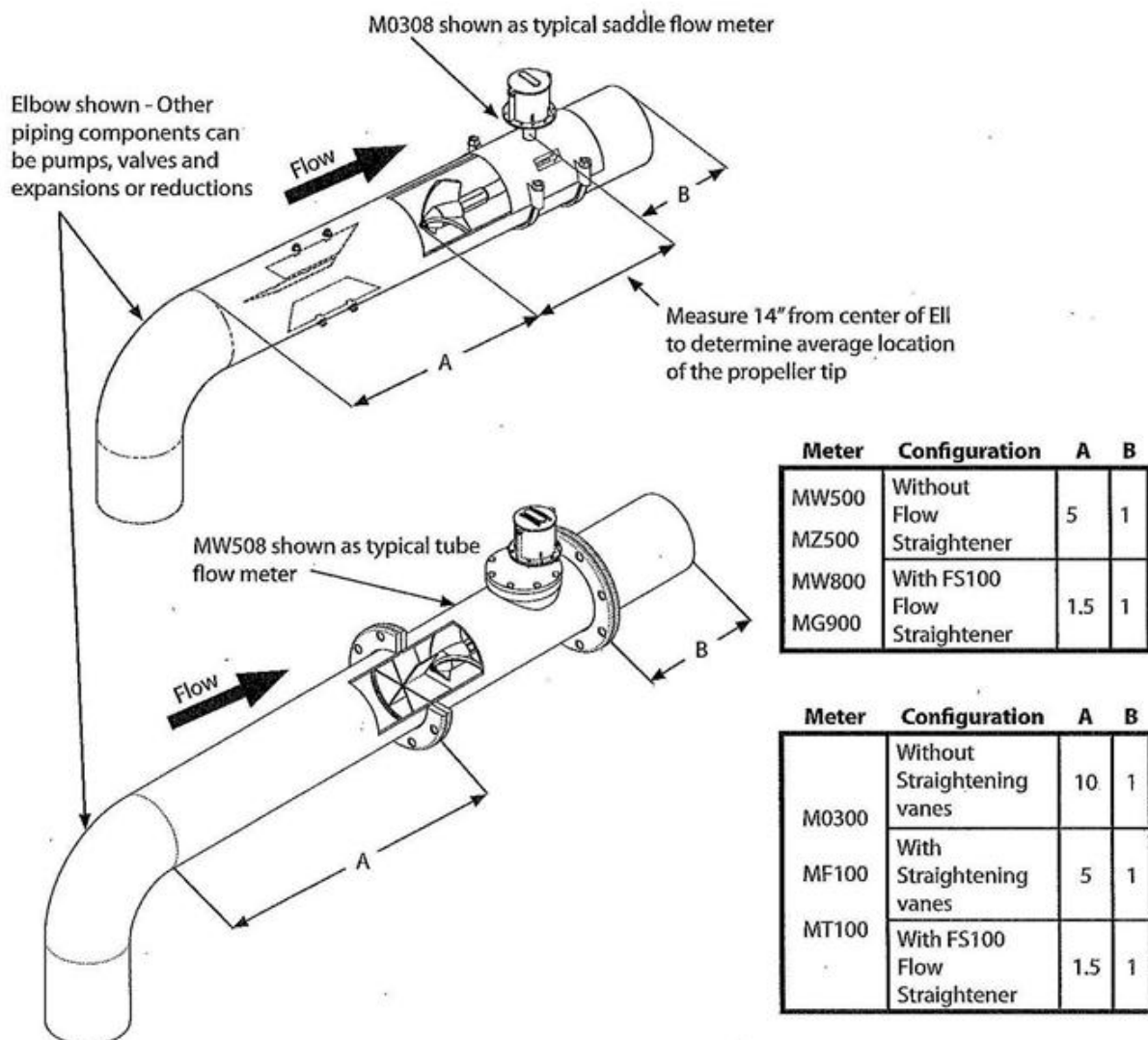
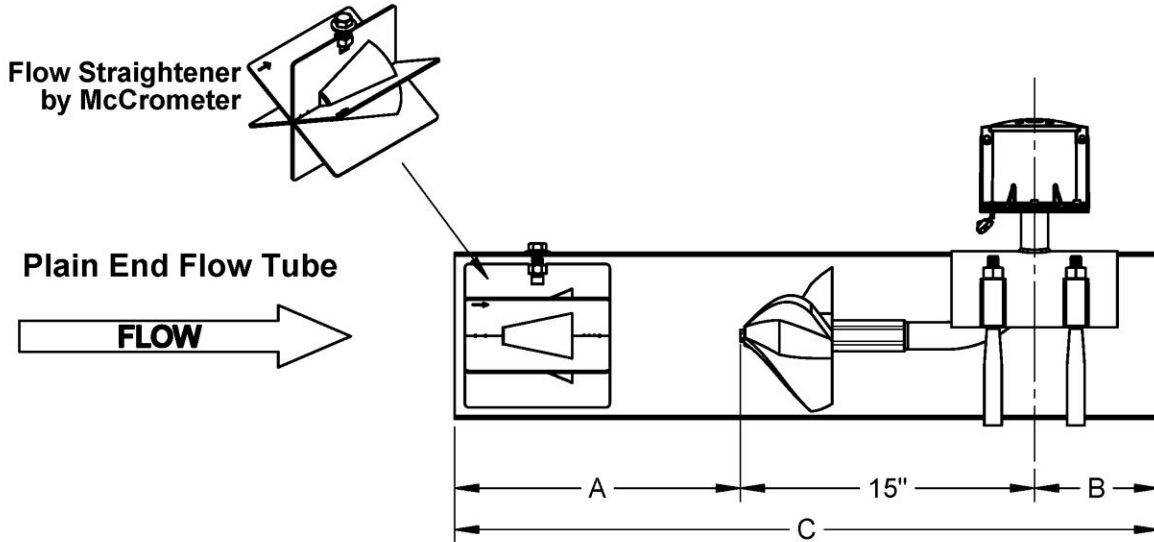

Figure: 5 Pipe Run Requirements For Saddle And Tube Style Flow Meters

UPPER BIG BLUE NATURAL RESOURCES DISTRICT
Approved Flow Meter List
 April 2026



**Flow Tubes with Flow Straightener
 in Forward Configuration**



Meter Tube Features

- Steel couplers can be welded to these tubes.
- Steel tubes are epoxy coated 10 Gauge.
- Tubes include total required lengths.
- Tubes can be fastened directly to check valves.
- Tubes can be Aluminum w/ couplers, flanges, or rolled ends.

Pipe Size	A	B	C
6	9	6	30
8	12	7	34
10	15	10	40
12	18	13	46

All dimensions are in inches

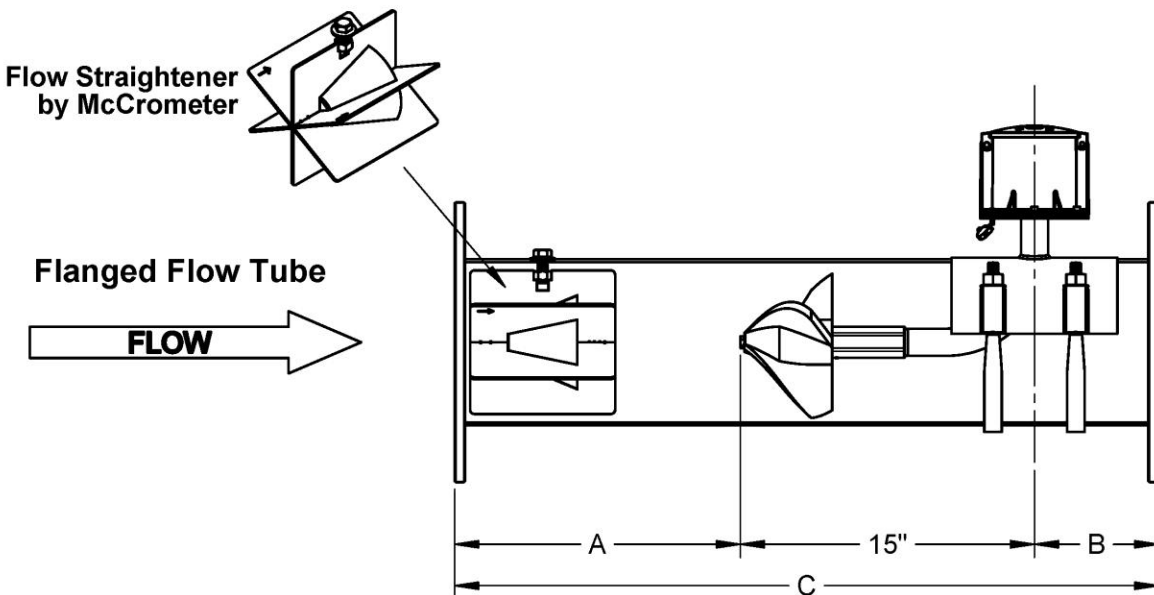

3255 WEST STETSON AVENUE • HEMET, CALIFORNIA 92545 USA
 TEL: 951-652-6811 • 800-220-2279 • FAX: 951-652-3078 Printed In The U.S.A.

www.mccrometer.com
 Lit. # 30123-64 Rev. 1.0 / 8-14-17

Copyright © 2016-2017 McCrometer, Inc. All printed material should not be changed or altered without permission of McCrometer. Any published technical data and instructions are subject to change without notice. Contact your McCrometer representative for current technical data and instructions.

UPPER BIG BLUE NATURAL RESOURCES DISTRICT
Approved Flow Meter List
April 2026

McCrometer McMag 3000 Electromagnetic Flow Meter

Straight Pipe Requirements

Flow meters are velocity sensing devices and are vulnerable to certain upstream disturbances. Because of this, meters need certain lengths of straight pipe before and after the meter. These distances relate to the diameter of the pipe used. Obstructions can include elbows, valves, pumps, and changes in pipe diameter. The uneven flow created by these obstructions can vary with each system.

Both upstream and downstream distances are measured from the center of the saddle as shown below.

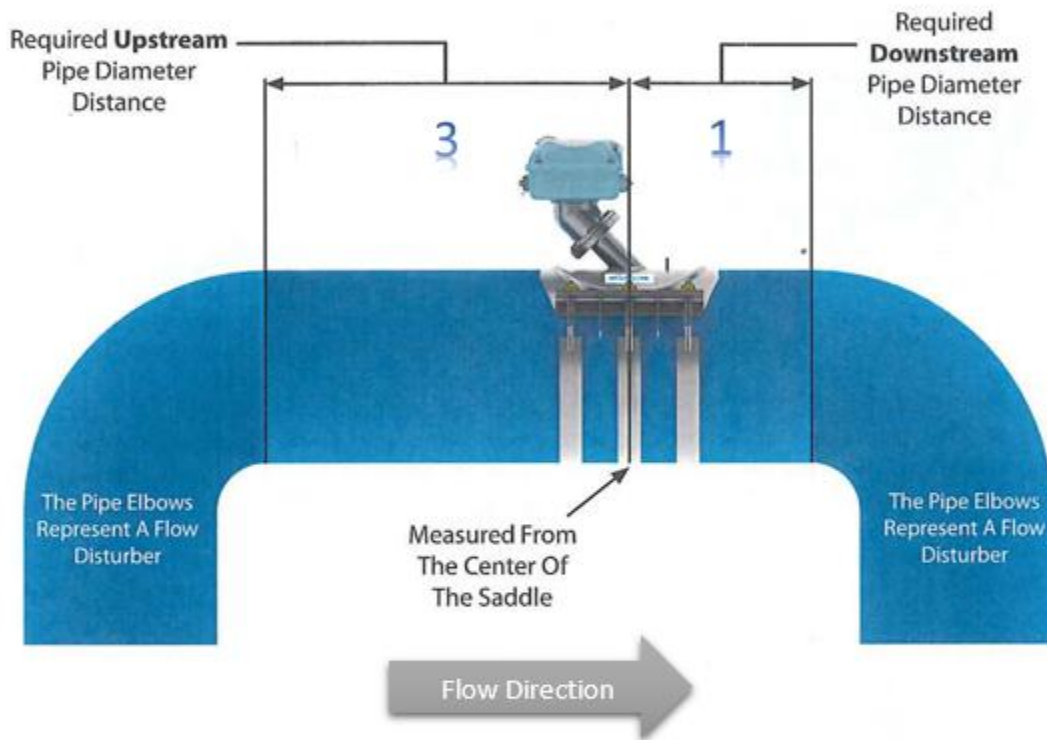

Figure 5: How To Measure Straight Pipe Requirements

In a typical installation, to achieve $\pm 2\%$ accuracy the Mc Mag ³⁰⁰⁰ flow meter should be installed a minimum of three diameters downstream of most disturbances and one diameter upstream of most disturbances. Accuracy of $\pm 1\%$ is available in many applications with a Factory consultation prior to ordering.

UPPER BIG BLUE NATURAL RESOURCES DISTRICT

Approved Flow Meter List

April 2026

McCrometer Dura Mag Electromagnetic Flow Meter

Available Sizes: 4" to 12"

Minimum Installation Requirements:

Jetting and Non-jetting flow - Minimum distance from both **jetting and non-jetting flow disturbances** is 2 pipe diameters upstream and 1 pipe diameters downstream of the flow meter.

Geyser Flow Meters (All models)

Minimum Installation Requirements:

Non-jetting flow - Minimum installation distance for non-jetting flow is 5 pipe diameters upstream and 2 pipe diameters downstream of the propeller. (Examples of things that may cause non-jetting flow include turbine pumps, pipe elbows, cooling coils).

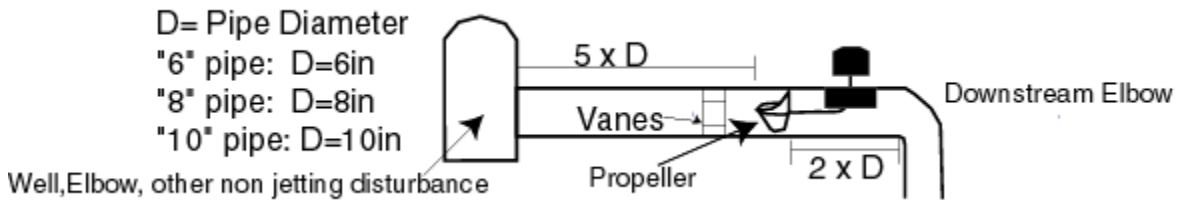

Jetting flow - Minimum installation distance for jetting flow is 10 pipe diameters upstream and 2 pipe diameters downstream of the propeller. (Examples of things that may cause jetting flow include pressure regulating valves, check valves and other in pipe restrictions).

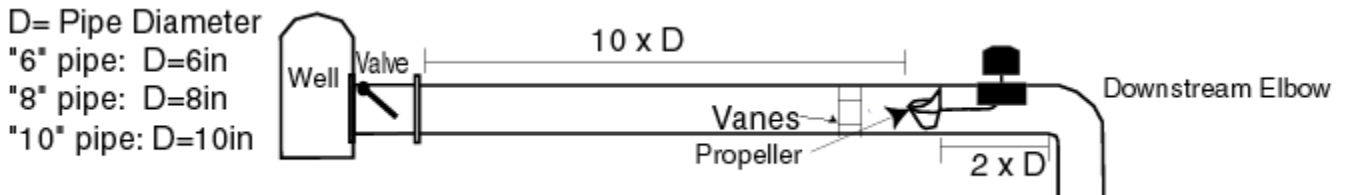

Straightening vanes are required for Geyser installations with a straight pipe run of 10 pipe diameters or less. (Straightening vanes are recommended on all installations).

ARAD WST - PERCISION – Woltman Silver Water Meter (NETAFIM USA)

Minimum Installation Requirements:

Jetting and Non-jetting flow - Minimum distance from **both jetting and non-jetting flow disturbances** is 5 pipe diameters upstream and 2 pipe diameters downstream of the flow meter.

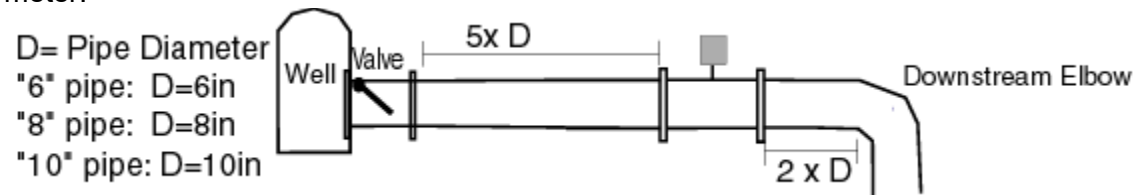

UPPER BIG BLUE NATURAL RESOURCES DISTRICT

Approved Flow Meter List

April 2026

ARAD IRT - Irrigation Water Meter (NETAFIM USA)

Minimum Installation Requirements:

Jetting and Non-jetting flow - Minimum distance from **both jetting and non-jetting flow disturbances** is 10 pipe diameters upstream and 5 pipe diameters downstream of the flow meter.

D= Pipe Diameter
"6" pipe: D=6in
"8" pipe: D=8in
"10" pipe: D=10in

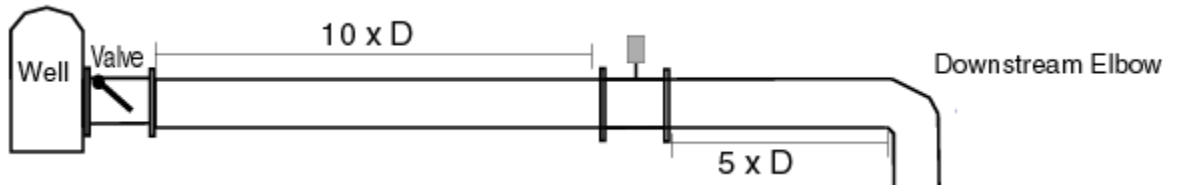

ARAD High Pressure Hydrometer Globe Type (BM)

Minimum Installation Requirements:

Jetting and Non-jetting flow - Minimum distance from both **jetting and non-jetting flow disturbances** is 1 pipe diameter upstream and 0 pipe diameters downstream of the flow meter.

D= Pipe Diameter
"6" pipe: D=6in
"8" pipe: D=8in
"10" pipe: D=10in

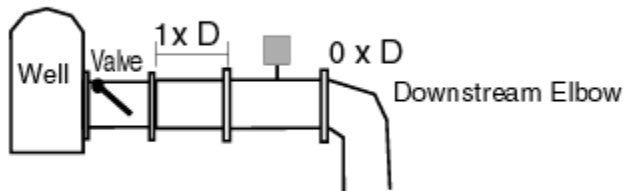

ARAD High Pressure Hydrometer Angle Type (BMA)

Minimum Installation Requirements:

Jetting and Non-jetting flow - Minimum distance from both **jetting and non-jetting flow disturbances** is 3 pipe diameter upstream and 2 pipe diameters downstream of the flow meter.

D= Pipe Diameter
"6" pipe: D=6in
"8" pipe: D=8in
"10" pipe: D=10in

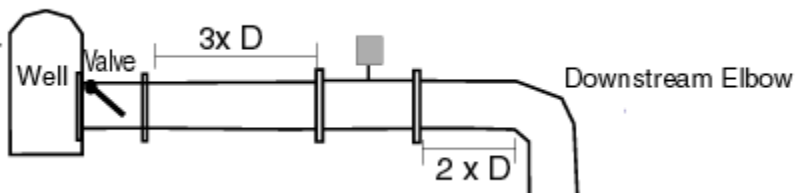

UPPER BIG BLUE NATURAL RESOURCES DISTRICT
Approved Flow Meter List
April 2026

ARAD – Octave Ultrasonic Water Meter

Minimum Installation Requirements:

- The water meter can be installed in any position
- The meter must be full with water all the time
- No special requirements for installation

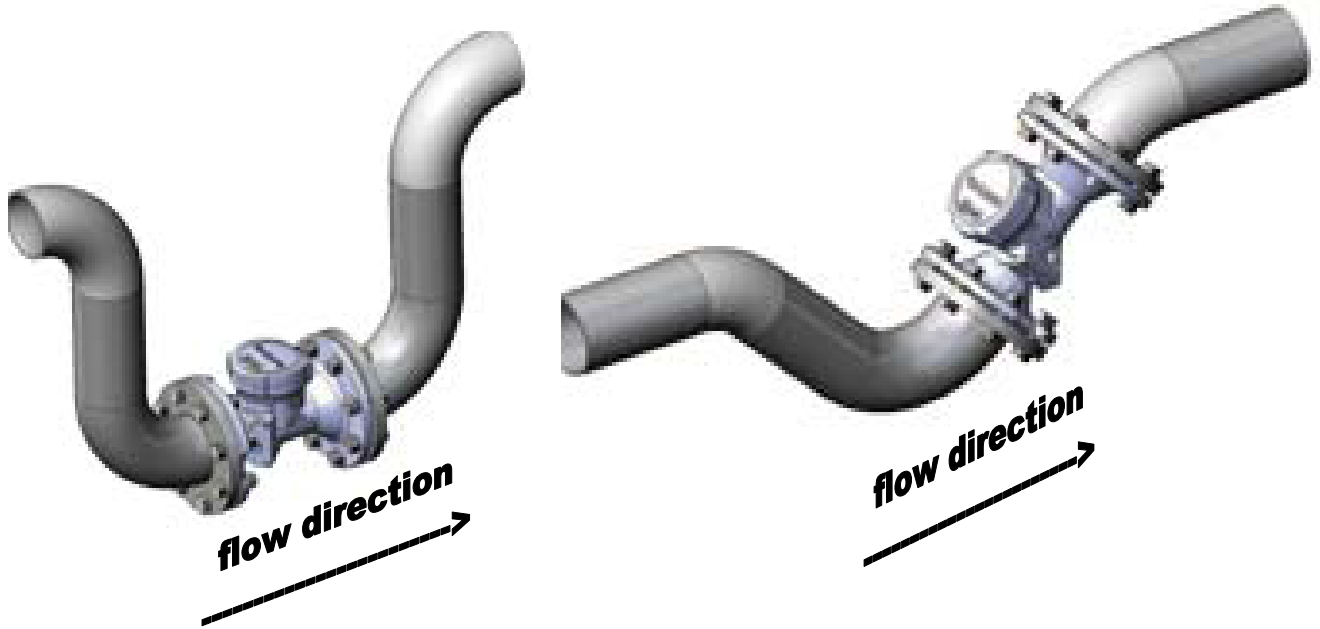

UPPER BIG BLUE NATURAL RESOURCES DISTRICT
Approved Flow Meter List
April 2026

Senninger Flo-Wise Ag Rotor Meter & Senninger Flow-Wise Magmeter

Minimum Installation Requirements:

Jetting and Non-Jetting Flow - Minimum installation distance is 5 pipe diameters upstream and 2 pipe diameters downstream of the flow meter in both jetting and non-jetting flow circumstances.

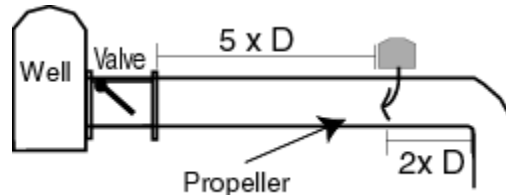

The Senninger Flo-Wise SC Ag Rotor Meter does not require straightening vanes.

SeaMetrics - AG1000/2000-Series Irrigation Magmeter

Minimum Installation Requirements:

Non-jetting flow (90 degree elbow) – The Seametrics AG 1000/2000 Series meter can be installed directly behind an elbow or well discharge. **Where available, optimal installation distance for non-jetting flow is at least 2 pipe diameters upstream and 1 pipe diameter downstream of the flow meter.**

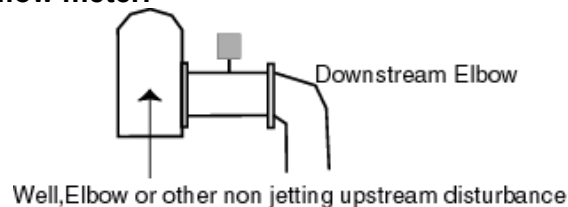

Jetting flow – The Seametrics AG 1000/2000 Series meter can be installed directly behind a jetting flow disturbance. **Where available, optimal installation distance for jetting flow is at least 5 pipe diameters upstream and 1 pipe diameters downstream of the flow meter.** (Examples of things that may cause jetting flow include pressure regulating valves, check valves and other in pipe restrictions).

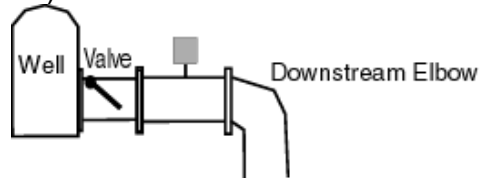

The AG1000/2000 Series Irrigation Magmeter does not require straightening vanes.

UPPER BIG BLUE NATURAL RESOURCES DISTRICT

Approved Flow Meter List

April 2026

SeaMetrics – AG3000 & Valley 3000 Magmeter

Minimum Installation Requirements:

Non-jetting flow (90 degree elbow) – The Seametrics AG 3000 & Valley 3000 Series meter can be installed directly behind an elbow or well discharge. **Where available, optimal installation distance for non-jetting flow is at least 2 pipe diameters upstream and 1 pipe diameter downstream of the flow meter.**

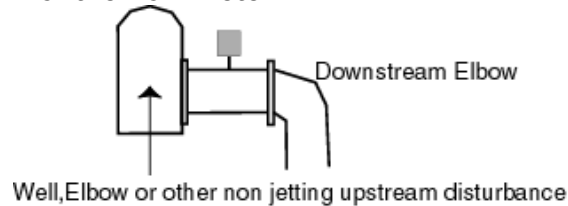

Jetting flow – The Seametrics AG 3000 & Valley 3000 Series meter can be installed directly behind a jetting flow disturbance. **Where available, optimal installation distance for jetting flow is at least 5 pipe diameters upstream and 1 pipe diameters downstream of the flow meter.** (Examples of things that may cause jetting flow include pressure regulating valves, check valves and other in pipe restrictions).

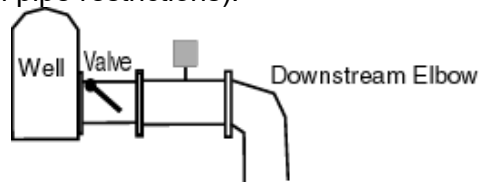

The AG1300 & Valley 3000 Series Irrigation Magmeter does not require straightening vanes.

SeaMetrics – AG90 Insertion Flow Meter

Choose a position that will ensure a full pipe.

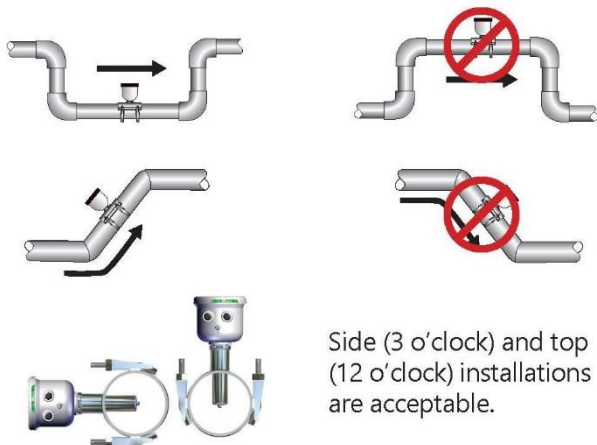

Choose a position that will minimize flow distortion.

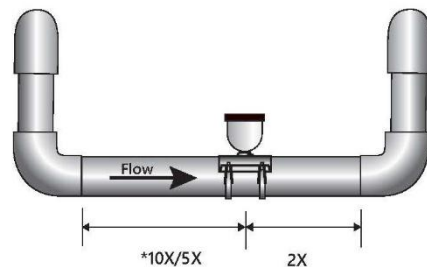

**Upstream straight pipe is selected during initial setup. Upstream options are 5X or 10X the diameter and are based on the amount of straight pipe available in either new or propeller meter replacement installation. Downstream straight pipe requirement is 2X the diameter. See programming setup for details.*

Flow Straightening Vanes/Conditioners

1. If you have the bolt-in, 3-vane style they may be removed or left in place. They do not affect performance.
2. If you have the 6-vane, bolt-in style with a cone, it should be removed.
3. For 6-vane, weld-in style installed in a spool, turn the spool 180° and reinstall with the vanes behind the meter.
4. Orifice, tube or Vortab style conditioners will not affect performance.

UPPER BIG BLUE NATURAL RESOURCES DISTRICT
Approved Flow Meter List
 April 2026

Seametrics – WMP104 Plastic Bodied Magmeter (2" & 3" models)

Minimum Installation Requirements: *Diagrams taken from document LT-65650290r1.2 20161006_10/6/16*

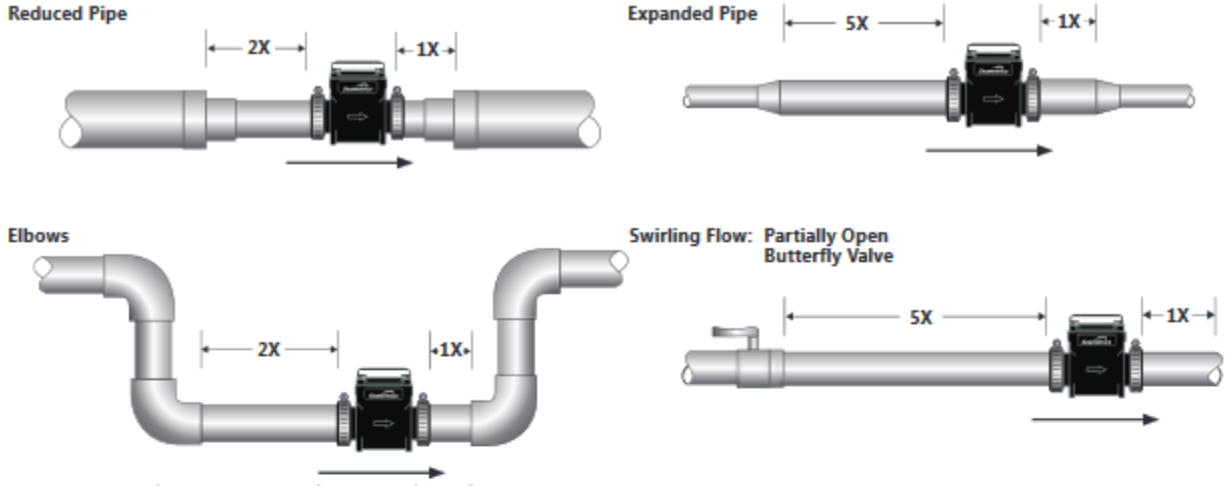

Full Pipe Recommendations

Possible Problem

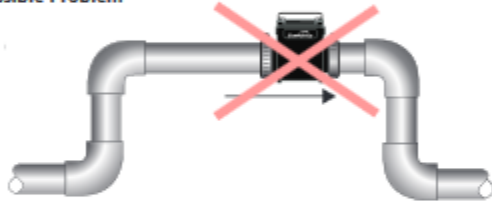

Allows air pockets to form at sensor

Better Installation

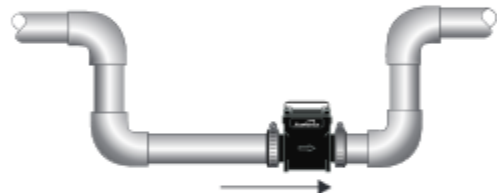

Ensures full pipe

Possible Problem

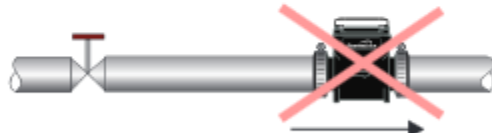

Post-valve cavitation can create air pocket

Better Installation

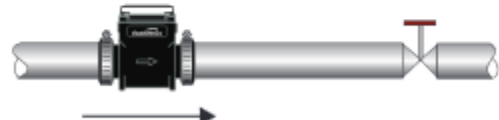

Keeps pipe full at sensor

Possible Problem

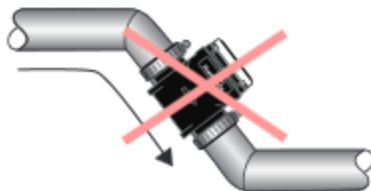

Air can be trapped

Better Installation



Allows air to bleed off

UPPER BIG BLUE NATURAL RESOURCES DISTRICT
Approved Flow Meter List
 April 2026



Meter Positioning

It is important to install flowmeters so the readings are always accurate. The meters are designed to give a zero reading, should one or more electrodes become exposed. Air bubbles and sediment in the pipe can cause false readings.

It is preferred that you install the flowmeter in a pipeline location where the pipe will be full when there is flow. Orientate the flow meter in a vertical position (meter positioned on top of the pipe) as well. Never install the flowmeter with the meter horizontal to the pipeline or below the pipe. The following diagram shows proper and improper meter positioning.

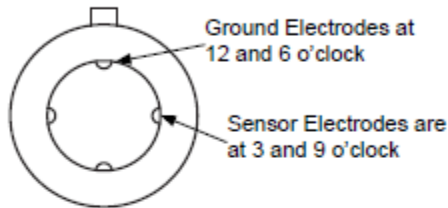

NOTE: Meters may be clocked up to 45° if necessary

Meter/Sensor Orientation

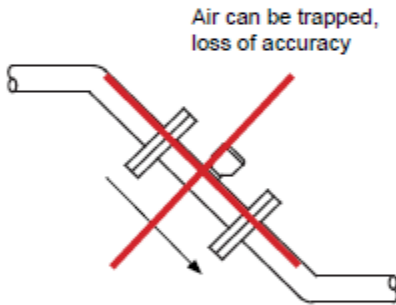

Problematic Meter Positioning

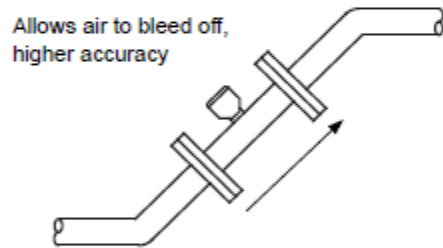

Recommended Meter Positioning

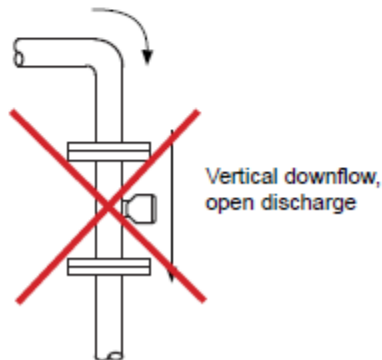

Problematic Meter Positioning

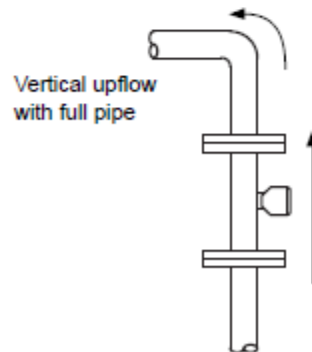

Recommended Meter Positioning

UPPER BIG BLUE NATURAL RESOURCES DISTRICT
Approved Flow Meter List
April 2026



Straight Pipe Recommendations

In order to achieve optimal meter accuracy and performance, it is necessary to provide sufficient lengths of straight pipe upstream and down stream from the IM3000 Flowmeter. The following are common examples of installation conditions and recommended minimum straight pipe lengths. These serve as general guidelines and do not cover all possible conditions or any specific local regulatory requirements. If there is a question with regards to a specific installation configuration, please contact the manufacturer for further support.

Pipe Elbow, Valve and Pump

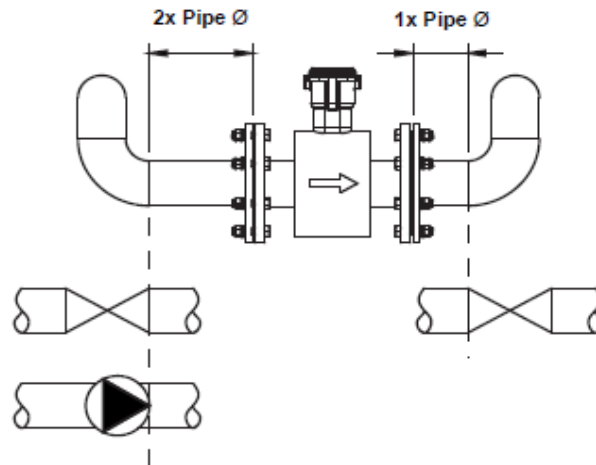

NOTE: Valve denotes a fully open butterfly or gate valve. When installed with a pump, the IM3000 should always be located downstream of the pump discharge. Installing meters upstream of a pump intake is generally not recommended.

Updated March 20, 2018

Summary:

This notice is to inform you that Lindsay has conducted thorough, controlled testing on the performance of the Growsmart IM3000 flow meter when close-coupled to 1) a 90-degree pipe elbow, 2) a vertical turbine discharge head, and 3) a swinging disc check valve. In each of these cases, the IM3000 was able to demonstrate +/-2% accuracy, despite having zero straight pipe upstream of its installation.

Background and Details:

Installing any make/model of electromagnetic flow meter with manufacturer recommended distances of upstream straight pipe is necessary for the meter to achieve its optimal accuracy. The IM3000 is capable of +/-1% measurement accuracy, when installed according to the straight pipe recommendations specified by the Growsmart installation manual, which is typically 2 pipe diameters (PD) upstream of the meter.

However, in certain agricultural installations, the piping configuration does not provide sufficient straight pipe. Lindsay has conducted thorough testing on the commonly seen installations below, and determined that in each case, the meter accuracy remains within +/-2%.



Zero Distance from Pipe Elbow



Zero Distance from Turbine
Pump Discharge



Zero Distance from Check
Valve

UPPER BIG BLUE NATURAL RESOURCES DISTRICT
Approved Flow Meter List
April 2026

Sparling BlueWater Electromagnetic Flow Meter

Minimum Installation Requirements:

3.2 Site Selection

Select a pipe location that will always be full of liquid. The equipment should be located where the flowmeter will be accessible for adjustment. Provide a minimum of 18" clearance to the electronics enclosure.

The meter may be located in any position from vertical to horizontal. Flow may be in either direction through the meter. When installing in a vertical direction, however, upflow of fluid is preferred to assure a full pipe condition.

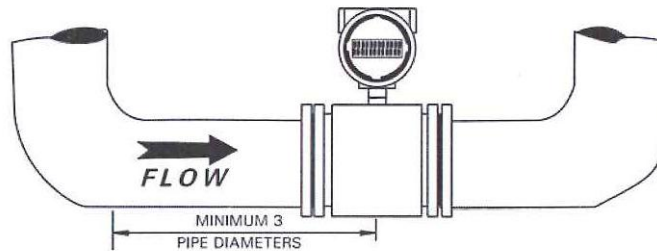

Figure 3.1

Horizontal installation requires that the sensing electrodes be positioned in the horizontal plane. See Figure 3.7.

Provide at least three pipe diameters of straight piping approach between an upstream elbow and the midpoint of the meter. More straight approach should be provided after valves or multiple elbows. Provide at least 10 diameters after expanders or laterals which are of smaller diameter than the line size.

UPPER BIG BLUE NATURAL RESOURCES DISTRICT

Approved Flow Meter List

April 2026

Sparling FM31/FT194 Low Pressure Bolt-on Propeller Flow Meter

Minimum Installation Requirements:

3.1 Site Selection Criteria

Choose a location that assures a pipe full of water flowing at or above minimum velocity for the meter. There should not be any enlargements, diffusers or obstructions upstream that would produce a jet or spiraling flow into the meter. 10 diameters of straight pipe upstream and 1 diameter downstream are recommended to avoid errors caused by skewed velocity profiles. See Figure 3.1

A jet caused by a partially opened valve, a centrifugal pump, or a pipe enlargement upstream from the meter can cause inaccurate registration.

Often such disturbances can be avoided by locating the meter on the suction side of the pump. The meter will register just as efficiently on a vertical or slanting pipe as on a horizontal line. The straightening vanes eliminate cork-screw effects in the flow profile. Flow conditioners may be required in installations where less than optimum conditions exist. See Figure 3.1

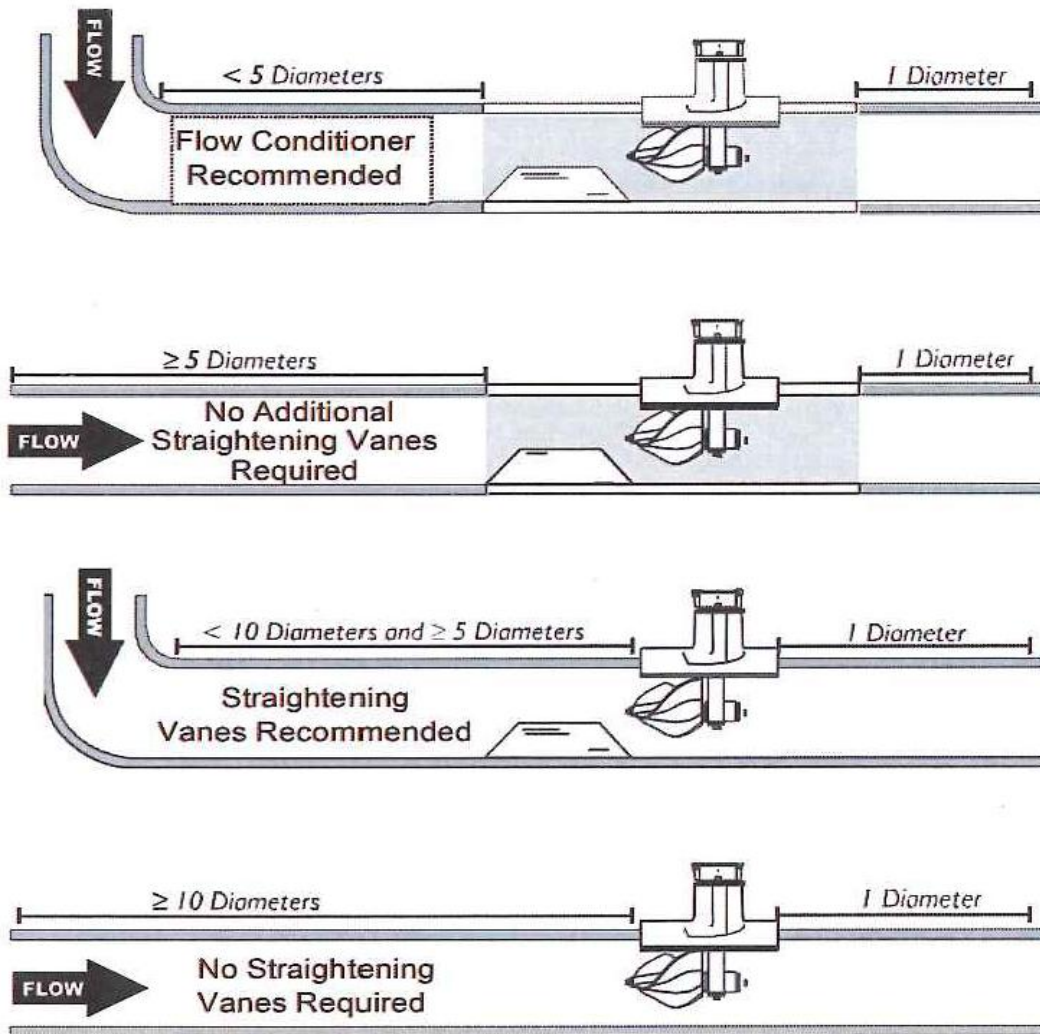

Figure 3.1
Installation Considerations

Bermad – M10 Electromagnetic Sensor Flow Meter

M10



Installation with no upstream and downstream distances

The M10 internal part of the sensor, allows an optimized and accelerated flow profile which permits to install the sensor in any kind of condition; no need to have straight sections/segments of pipes upstream and downstream. This U0-D0 condition enables to have an extreme flexibility on the flow meter installation position.

Standards reference

The M10 electromagnetic meters are marked CE and are manufactured according to the following standards:

- 2014/53/EU
- 2014/30/EU - EN 61326-1:2013 (EMC)
- 2014/65/EU
- EN IEC 60529
- OIML R49-1:2013
- European directive 2014/32/EU (MID)
- NSF

UPPER BIG BLUE NATURAL RESOURCES DISTRICT
Approved Flow Meter List
 April 2026

M10

Technical features M10

FEATURES	M10	
Structure	Integral Flow meter	
DN Range	2" - 6"	
Nominal Pressure	250 PSI	
Process Connection	Victaulic OGS	
Fluid Conductivity	> 20 µS/cm	
Process Temperature Range	32 - 176 °F	
Materials in contact with water	Flow tube: Glass fibre reinforced plastic Electrodes: AISI316L	
Power supply	Battery Powered: 3.6 V Lithium Battery Mains Powered: 12Vdc (10.8 - 13.2V), max 100mA	
Consumption	0.25W-1W (Mains powered)	
Outputs	2 passive outputs (1 programmable), SSR Type (dry contact), galvanically insulated Max. load +/- 35VDC, 100 mA protected against short circuits, minimum pulse duration 5ms. RS485 2 wire /half-duplex	
Communication	Modbus RTU Slave Bluetooth	
Display	LCD Segment display, with dedicated status icons, 8+6 digits	
User Interfaces	Magnetic reed Bluetooth Mobile App Euromag Link Software	
Process memory	100,000 data lines Programmable frequency 1 - 120 minutes (15 minutes factory standard)	
Metrological certificate	OIML R49-1:2013 / MID 2014/32/EU - Class 2 (if requested)	
Temperature range	Ambient: -4 - 140 °F Process: 32 - 176 °F Storage: -40 - 158 °F	
Technical units	m, m3, l, ML, ft3, gal, AC FT, AC IN	
Totalizers	5 (2 Positive, 2 Negative, 1 Net)	
Alarms and status icons	Status icons displayed and alarms recorded in the data logger	
Self diagnostic	Excitation failure Excessive ambient temperature Wet electronic board Low battery level / Mains voltage out of range Pulses overlapping	Bluetooth communication error Empty pipe Measurement error Software/memory malfunction Mains power interruption
Software for communication and programming	Bluetooth Mobile App - Mag-Net Euromag Link Software (through Bluetooth dongle, or RS485 interface)	
Data Protection	Customizable password protection EEPROM Memory with safe data storage management	

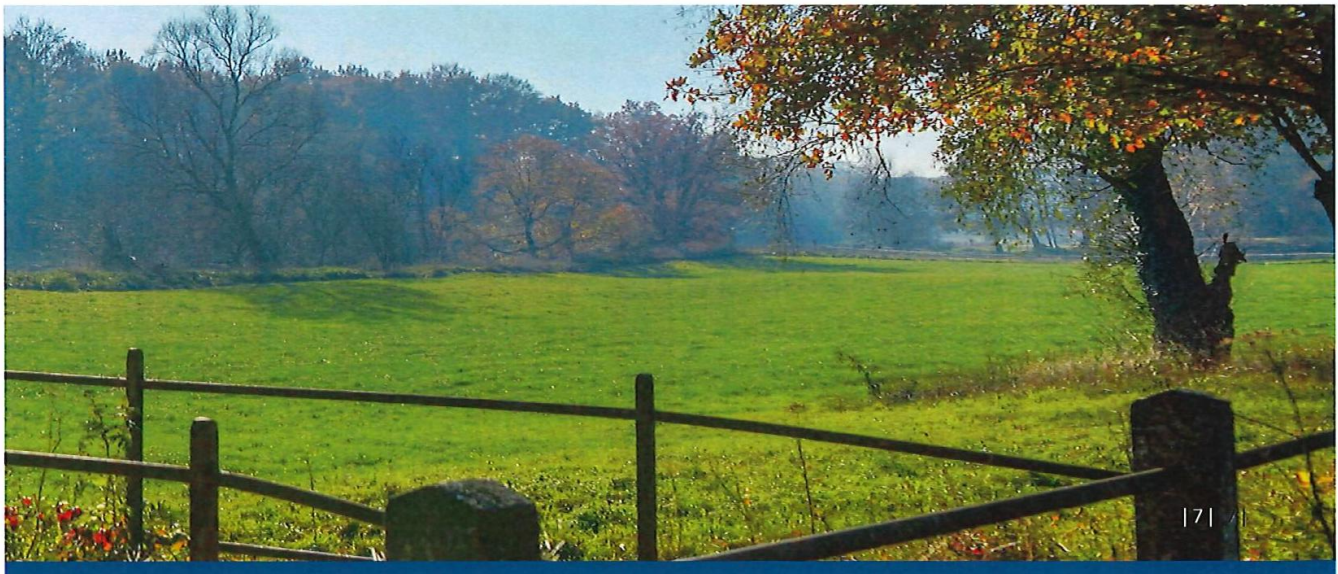

UPPER BIG BLUE NATURAL RESOURCES DISTRICT
Approved Flow Meter List
 April 2026

M10

Overall Dimensions

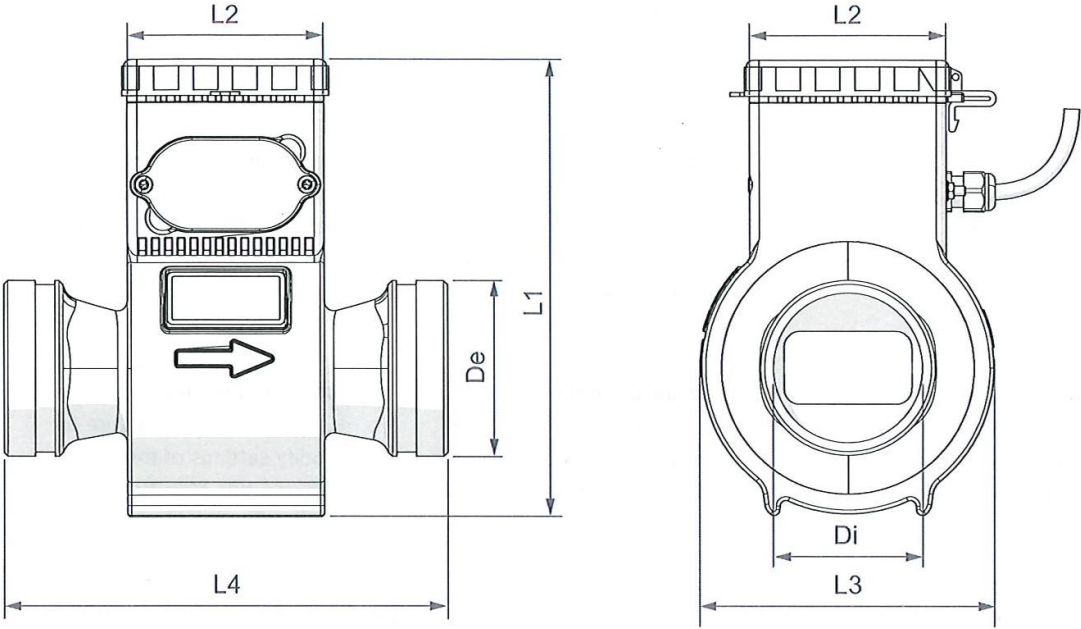

Size	De	L1	L2	L3	L4
2"	2.36	9.05	3.93	5.90	7.87
3"	3.46	9.05	3.93	5.90	8.58
4"	4.50	9.05	3.93	5.90	9.84
6"	6.62	11.8	3.93	8.26	11.8

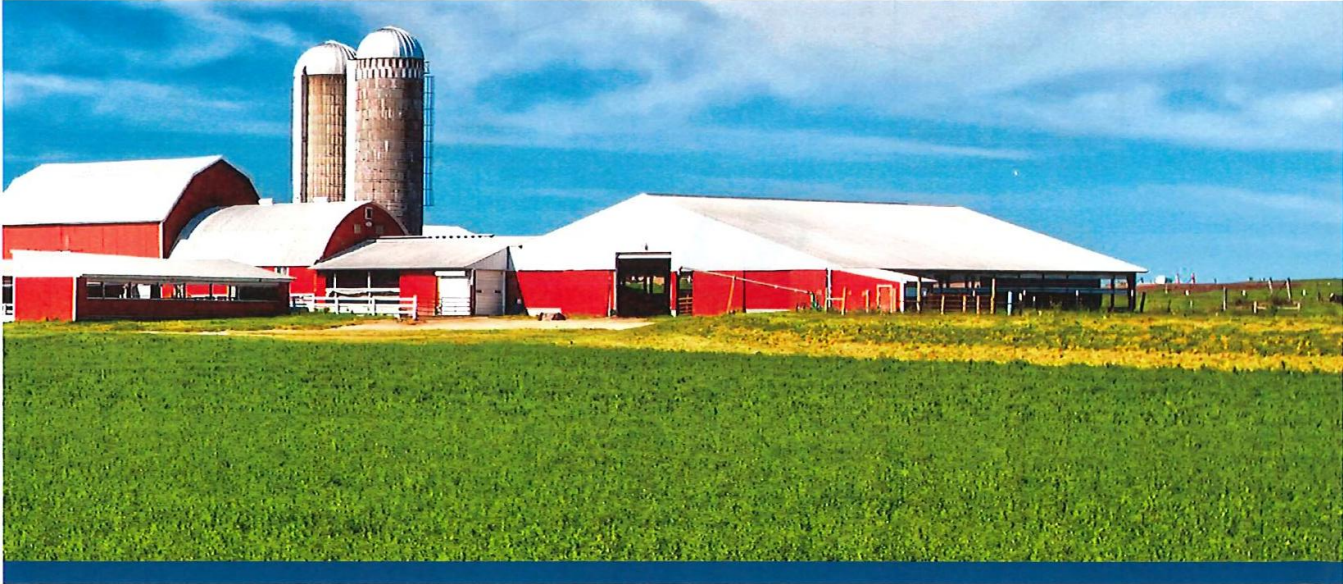

UPPER BIG BLUE NATURAL RESOURCES DISTRICT
Approved Flow Meter List
April 2026

Bermad – MUT2300/MC406 Electromagnetic Flow Meter



The MUT2300 with MC406 is a battery powered electromagnetic water meter for use in district metering areas (DMA), water abstraction, and custody transfer measurement of potable water (MI-001, OIML R49), irrigation, and many other applications. Unlike other water meters, the MUT2300 is a maintenance-free meter, offering a much wider range of flow, in a compact or remote mounted version. Thanks to the optimized flow profile, the MUT2300 can be installed virtually anywhere without straight inlet or outlet runs, behind pipe bends, slide valves or a reduction in the pipe. Its measuring tube is in fact specifically designed to enable a stable measurement even at the lowest flow rates, maintaining a neglectable pressure loss in all its range. With optional pressure and temperature sensors, GSM/GPRS integrated modem and 12...24Vdc power source, the meter is the perfect solution for leak detection, and pressure management systems. The highly robust structure, allows burial installation or the use in flooded areas. A full on-site verification without process interruption can be carried out using the Field Vericator service tool.

Applications

- District metering of potable water
- Distribution, municipal water
- Industrial waste water
- Overnight applications with very low flow rate
- Industrial process liquids, muds and concretes
- Installation in small places without straight distances
- Leak detection and monitoring
- Fiscal measures, custody transfer
- Irrigation
- Booster pump stations
- Lift stations

Key advantages

- No moving parts
- Neglectable pressure drop
- Long lasting stability and precision
- Zero maintenance
- Extremely sturdy structure
- High chemical resilience
- Wider range of measurement

Product's benefit

High performances to a low cost of ownership: Capability to read flow velocities of 0.015 m/s (MID-001 OIML R49 certified), within Class 1 accuracy

Up to 10 years of battery life: High-efficiency, technologically advanced battery powered converter

U0-D0: Zero upstream and downstream distances (MID-001 OIML R49 certified)

No data lost: Data automatically stored in the internal EEPROM memory. Up to 100.000 lines of active datalogging

Information always available: Add-on communication module GSM/GPRS automatically sends the information via SMS, e-mail or on a website portal www.euromagdata.com with personal ID and password. Accessible also from smart phones and tablets. Configurable FTP communication.

Empty pipe detection: Empty pipe electrode supplied as standard (\geq DN65). Empty pipe detection on measuring electrodes standard for all sizes

Flow - pressure – temperature: all at the same time: Add on modules of temperature and pressure readying make the MUT2300 with MC406 one of the most complete electromagnetic flowmeter available in the market

Easy management, easy programming: A software is supplied with the unit to allow users to communicate with the MC406 via IRCOM port to any pc, lap top or windows tablet.

Certifications and compliance: OIML R49-MID Class 1 (on request) / EX - IEC IECEx (on request and only separate version) / NSF ANSI61 (On model MUT2300US)

Always verified: The Euromag FIELD VERIFICATOR is available for full on-site verification, without interruption of the process

UPPER BIG BLUE NATURAL RESOURCES DISTRICT
Approved Flow Meter List
April 2026

MUT2300 | MC406

Features

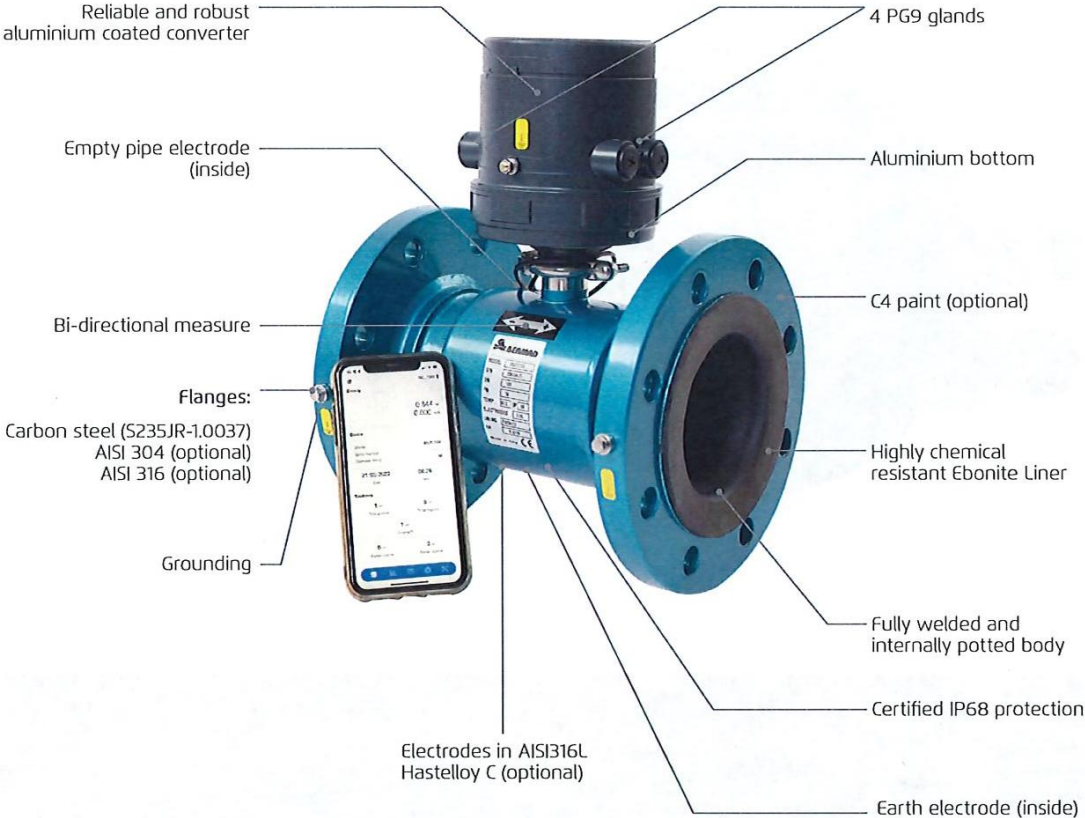

UPPER BIG BLUE NATURAL RESOURCES DISTRICT
Approved Flow Meter List
April 2026



Features

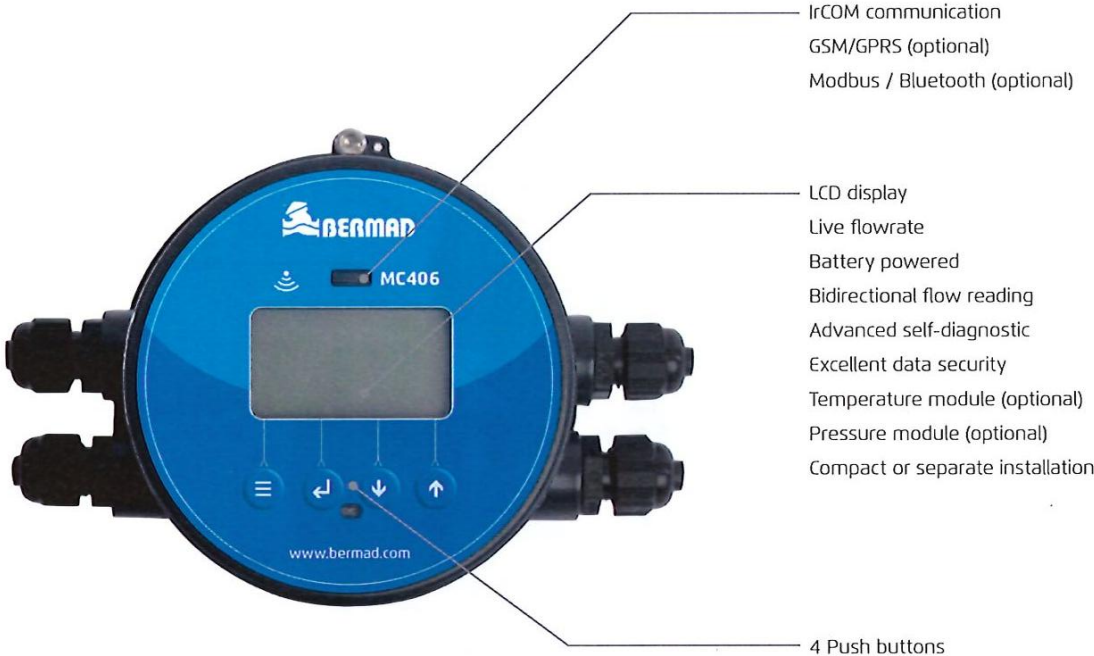

UPPER BIG BLUE NATURAL RESOURCES DISTRICT
Approved Flow Meter List
April 2026

The following meters are approved for *non-irrigation* applications only*

Elster AMCO Water evoQ4 Electromagnetic water meter

Minimum Installation Requirements:

- The pipe must always be filled completely with the flowing fluid.

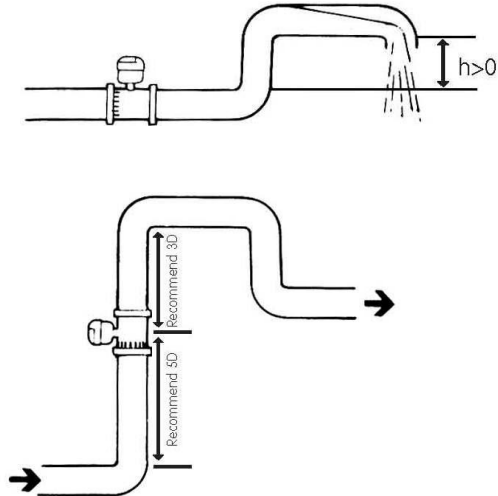

When installing the meter on vertical piping, make sure to mount it on a pipe section in which the fluid flows upwards.

UPPER BIG BLUE NATURAL RESOURCES DISTRICT
Approved Flow Meter List
April 2026

- A straight section of the pipe is recommended for meter installation.

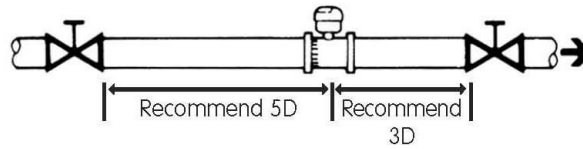

During fully open position using various valves; the meter can be fixed directly to a gate valve being fully opened.



Applicable to various control valves, such as butterfly and ball valves.

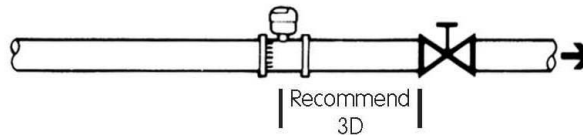

Be sure to install control valves towards the lower end of the downward flow as possible.

Hays Turbine Meter - WP Series

Minimum Installation Requirements:

Minimum installation distance is 5 pipe diameters upstream and 3 pipe diameters downstream of the flow meter.

Master Meter – Multi-Jet Water Meters (5/8” thru 2” sizes)

Minimum Installation Requirements:

A low pressure loss shutoff valve must be installed upstream and downstream of the meter.

The meter must be installed in horizontal plane, with the register upright, in a location accessible for reading, service and inspection.

Manufacturer design and installation instructions must be followed for these meters.

GPI A1 Commercial Grade Meters – A100, A200 and N100

Minimum Installation Requirements:

Avoid installing the meter in electrically “noisy” environments.

Minimum installation distance for A100 and N100 (1” size) is 20 inches upstream and 5 inches downstream of the flow.

Minimum installation distance for A200(2” size) is 40 inches upstream and 10 inches downstream of the flow.

UPPER BIG BLUE NATURAL RESOURCES DISTRICT
Approved Flow Meter List
April 2026

Neptune High Performance Turbine Meter

Minimum Installation Requirements:

Installations without the Neptune strainer require a minimum installation distance of 6 pipe diameters downstream from flow disturbances.