



# UPPER BIG BLUE Natural Resources District

319 East 25<sup>th</sup> Street  
York, Nebraska 68467

402-362-6601  
Fax: 402-362-1849  
www.upperbigblue.org

## Approved Flow Meter List July 2025

Water meters are critical in implementing accurate future water usage reporting and possibly allocation. In order to ensure accuracy, UBBNRD follows manufacturers' minimum installation requirements for specific brands of meters. These requirements are outlined in the following pages of this packet. **The following are some guidelines that can simplify the installation process and ensure you an accurate and useful meter:**

**Minimum distances:** If your current plumbing setup has MORE straight run distance than the minimum required, use that extra distance to install the meter **as far away as possible** from disturbances (particularly upstream disturbances) to ensure optimum accuracy. Remember, many requirements you will find in this packet are minimum, not optimum.

**Types of Disturbances:** Different flow altering devices (valves, etc) and fittings (elbows) create differing flow conditions. Valves typically produce a jetting flow condition, while fittings such as elbows create a non-jetting flow condition. Also, consider pipe size alterations such as reducers or increasers to exhibit non-jetting and jetting flow conditions, respectively. Most meters have different minimum installation requirements for each type of flow condition, and therefore, you will need to understand what flow conditions will exist in your installation. If you do not plan to install the meter yourself, be ABSOLUTELY SURE that your meter installer is familiar with installation requirements for your particular meter and plumbing situation.

**Choosing the right meter:** If you purchase a propeller type meter it is important that you have it calibrated to the correct inside pipe diameter. As a velocity-sensing device, the principle behind a flow meter is calculating flow volume by using the relationship between inside pipe diameter and flow velocity. An accurate flow volume is calculated by correctly calibrating the meter to the inside diameter of the pipe it is installed in. Also, for irrigation systems, you must purchase a meter model that totalizes in **acre-inches** (the rate of flow needle will still read GPM flow). This meter will be much more convenient (requiring less calculation) to read for reporting and irrigation management purposes. If applicable (depending on the type of meter) it must contain an **anti-reverse feature**.

**Maintenance:** Refer to the owner's manual that comes with your meter and follow maintenance recommendations. Particularly for propeller meters, periodic maintenance is critical to meter life. Keeping a meter in good condition will result in reliable readings that can be used both for reporting purposes and for checking and maintaining an efficient irrigation system. Electronic flow meters also require some maintenance. Batteries must be replaced on a regular schedule to reduce the risk of losing data during the irrigation season. **It is important to check to see if the meter is working each time you start and stop the irrigation system.**

Sincerely,

Terry Julesgard  
Water Department Manager  
UBBNRD

## UPPER BIG BLUE NATURAL RESOURCES DISTRICT

### Approved Flow Meter List

July 2025

The following flow meters are approved for use to record groundwater withdrawals required by the District's Groundwater Management Area Rules and Regulations. An approved flow meter must be installed when it is required by the District's Ground Water Management Area Rules and Regulations or when the District is providing cost-share assistance for the flow meter.

#### **Meters approved for ALL groundwater measurement applications**

McCrometer Propeller Flow meters (All models)  
McCrometer McMag3000 Electromagnetic Flow Meter  
McCrometer Dura Mag Electromagnetic Flow Meter  
Geyser Flow Meter (All models)  
ARAD WST - PERCISION – Woltman Silver Water Meter  
ARAD IRT - Irrigation Water Meter  
ARAD High Pressure Hydrometer Globe Type (BM)  
ARAD High Pressure Hydrometer Angle Type (BMA)  
ARAD Octave Ultrasonic  
Senninger Flo-Wise Ag Rotor Meter  
Senninger Flo-Wise Magmeter  
SeaMetrics – AG1000/2000-Series Irrigation Magmeter  
SeaMetrics – AG3000 & Valley 3000 Magmeter  
SeaMetrics – AG90 Insertion Flow Meter  
SeaMetrics – WMP104 Plastic Bodied Magmeter (2" & 3" models only)  
Growsmart by Lindsay – IM3000 Magnetic Flow Meter  
Sparling BlueWater Electromagnetic Flow Meter  
Sparling FM31/FT194 Low Pressure Bolt-on Propeller Flow Meter  
Bermad – M10 Electromagnetic Sensor Flow Meter  
Bermad – MUT2300/MC406 Electromagnetic Flow Meter

#### **Meters approved for non-irrigation applications only\***

Hays Turbine Meter – WP Series  
Master Meter – Multi-Jet Water Meters (5.8" thru 2" sizes)  
GPI Commercial Grade Meters – A100, A200 and N100  
Neptune High Performance Turbine Meter  
Elster AMCO Water evoQ4 Electromagnetic water meter

\* Use associated with an irrigation system will be considered on a case by case basis

UPPER BIG BLUE NATURAL RESOURCES DISTRICT

Approved Flow Meter List

July 2025

The following meters are approved for **ALL** groundwater measurement applications

**McCrometer Propeller Flow Meters (all models)**

Minimum Installation Requirements:

Flowmeters are velocity sensing devices and are vulnerable to certain upstream disturbances. Because of this, meters need certain lengths of straight pipe runs before and after the meter. These distances usually relate to the diameter of the pipe used. Obstructions can include elbows, valves, pumps, and changes in pipe diameter. The uneven flow created by these obstructions can vary with each system. If your application provides for more than five diameters of upstream run, use the available distance.

- **Minimum Upstream Requirement:** Mc Propeller meters should be installed **a minimum of five to ten times the diameter of the pipe downstream of any obstructions. See the diagram and corresponding tables below.** The exact upstream straight-pipe requirement is specific to the meter model number.
- **Minimum Downstream Requirement:** Mc Propeller meters should be installed **a minimum of one to two times the diameter of the pipe upstream of any obstructions.**

For upstream and downstream piping requirements relating to your specific meter, contact your local McCrometer representative. (Please be prepared to provide the serial number of your meter.)

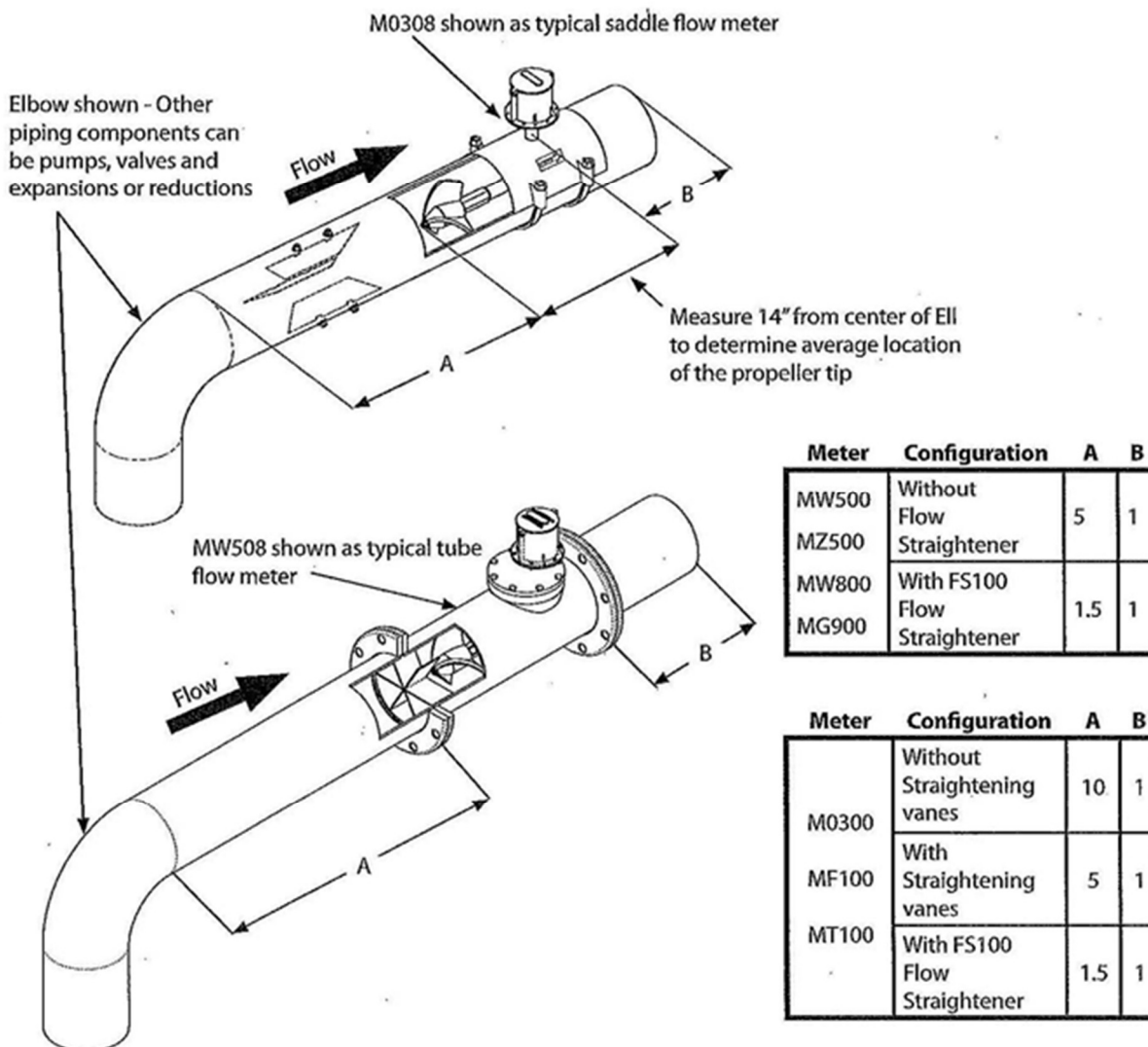

Figure: 5 Pipe Run Requirements For Saddle And Tube Style Flow Meters

UPPER BIG BLUE NATURAL RESOURCES DISTRICT  
Approved Flow Meter List  
July 2025

**McCrometer McMag 3000 Electromagnetic Flow Meter**

**Straight Pipe Requirements**

Flow meters are velocity sensing devices and are vulnerable to certain upstream disturbances. Because of this, meters need certain lengths of straight pipe before and after the meter. These distances relate to the diameter of the pipe used. Obstructions can include elbows, valves, pumps, and changes in pipe diameter. The uneven flow created by these obstructions can vary with each system.

Both upstream and downstream distances are measured from the center of the saddle as shown below.

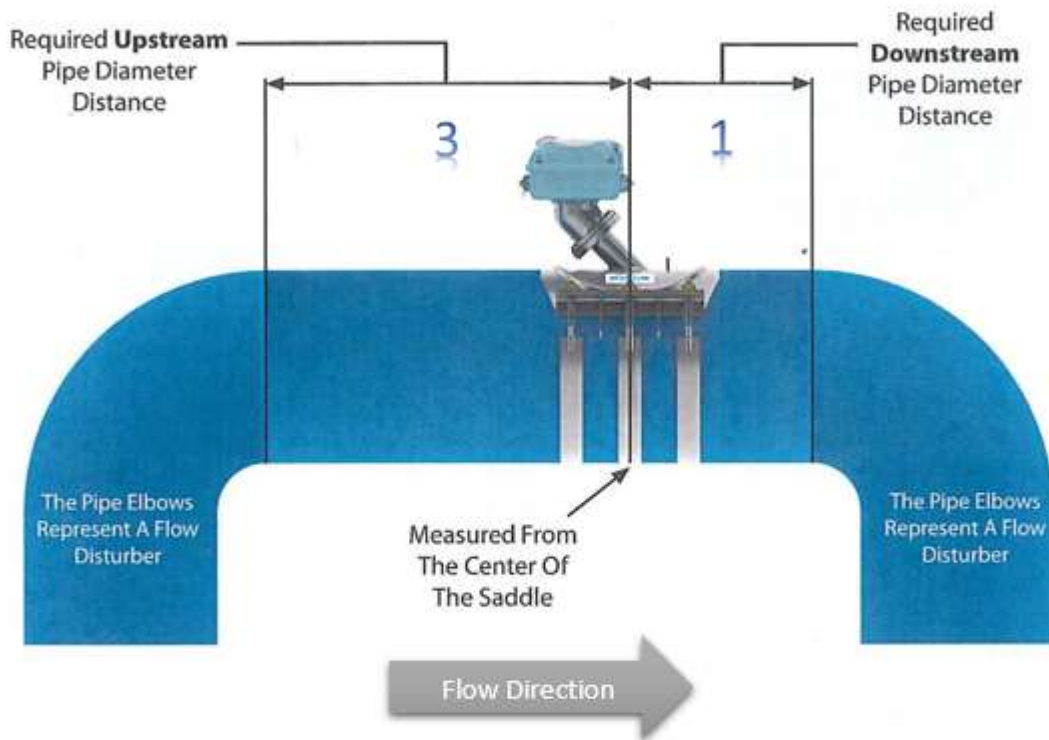

Figure 5: How To Measure Straight Pipe Requirements

In a typical installation, to achieve  $\pm 2\%$  accuracy the Mc Mag <sup>3000</sup> flow meter should be installed a minimum of three diameters downstream of most disturbances and one diameter upstream of most disturbances. Accuracy of  $\pm 1\%$  is available in many applications with a Factory consultation prior to ordering.

UPPER BIG BLUE NATURAL RESOURCES DISTRICT

Approved Flow Meter List

July 2025

**McCrometer Dura Mag Electromagnetic Flow Meter**

Available Sizes: 4" to 12"

Minimum Installation Requirements:

**Jetting and Non-jetting flow** - Minimum distance from both **jetting and non-jetting flow disturbances** is 2 pipe diameters upstream and 1 pipe diameters downstream of the flow meter.

**Geyser Flow Meters (All models)**

Minimum Installation Requirements:

**Non-jetting flow** - Minimum installation distance for non-jetting flow is 5 pipe diameters upstream and 2 pipe diameters downstream of the propeller. (Examples of things that may cause non-jetting flow include turbine pumps, pipe elbows, cooling coils).

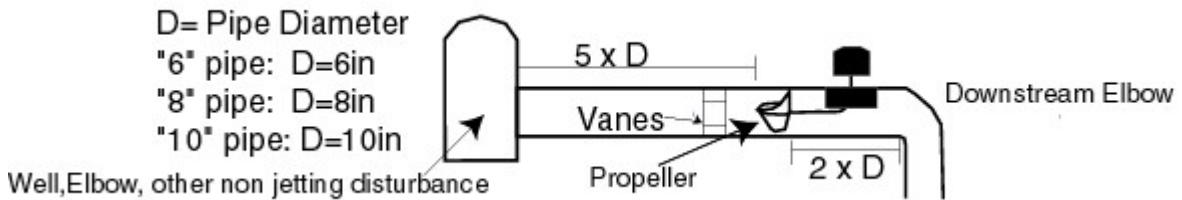

**Jetting flow** - Minimum installation distance for jetting flow is 10 pipe diameters upstream and 2 pipe diameters downstream of the propeller. (Examples of things that may cause jetting flow include pressure regulating valves, check valves and other in pipe restrictions).

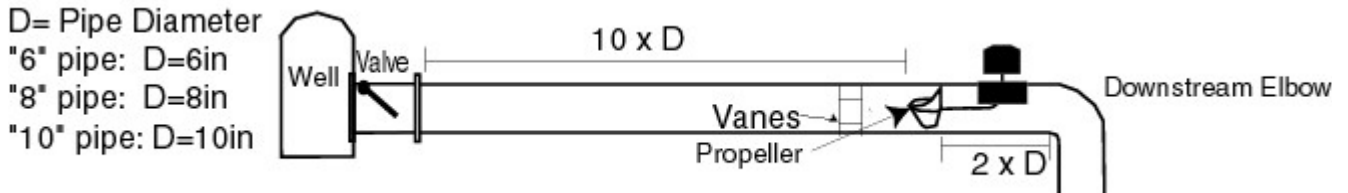

**Straightening vanes are required for Geyser installations with a straight pipe run of 10 pipe diameters or less. (Straightening vanes are recommended on all installations).**

**ARAD WST - PERCISION – Woltman Silver Water Meter (NETAFIM USA)**

Minimum Installation Requirements:

**Jetting and Non-jetting flow** - Minimum distance from **both jetting and non-jetting flow disturbances** is 5 pipe diameters upstream and 2 pipe diameters downstream of the flow meter.

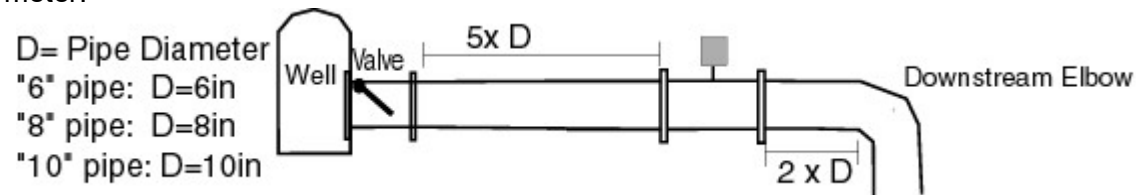

UPPER BIG BLUE NATURAL RESOURCES DISTRICT

Approved Flow Meter List

July 2025

**ARAD IRT - Irrigation Water Meter (NETAFIM USA)**

Minimum Installation Requirements:

**Jetting and Non-jetting flow** - Minimum distance from **both jetting and non-jetting flow disturbances** is 10 pipe diameters upstream and 5 pipe diameters downstream of the flow meter.

D= Pipe Diameter

"6" pipe: D=6in

"8" pipe: D=8in

"10" pipe: D=10in

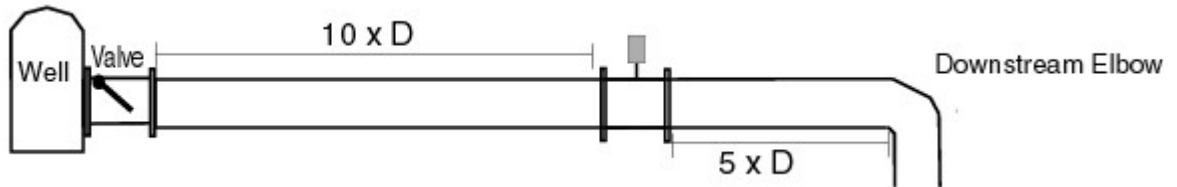

**ARAD High Pressure Hydrometer Globe Type (BM)**

Minimum Installation Requirements:

**Jetting and Non-jetting flow** - Minimum distance from both **jetting and non-jetting flow disturbances** is 1 pipe diameter upstream and 0 pipe diameters downstream of the flow meter.

D= Pipe Diameter

"6" pipe: D=6in

"8" pipe: D=8in

"10" pipe: D=10in

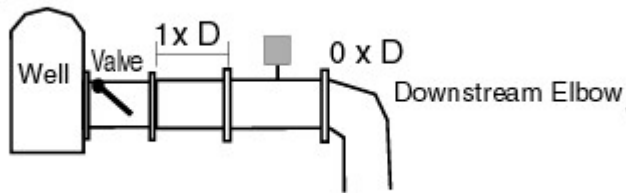

**ARAD High Pressure Hydrometer Angle Type (BMA)**

Minimum Installation Requirements:

**Jetting and Non-jetting flow** - Minimum distance from both **jetting and non-jetting flow disturbances** is 3 pipe diameter upstream and 2 pipe diameters downstream of the flow meter.

D= Pipe Diameter

"6" pipe: D=6in

"8" pipe: D=8in

"10" pipe: D=10in

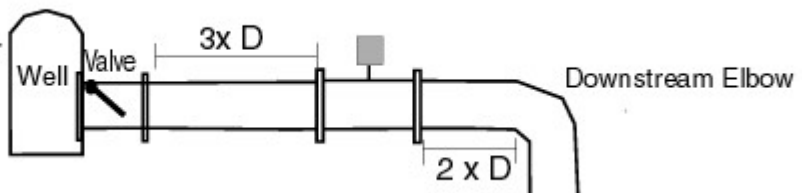

UPPER BIG BLUE NATURAL RESOURCES DISTRICT  
Approved Flow Meter List  
July 2025

**ARAD – Octave Ultrasonic Water Meter**

Minimum Installation Requirements:

- The water meter can be installed in any position
- The meter must be full with water all the time
- No special requirements for installation

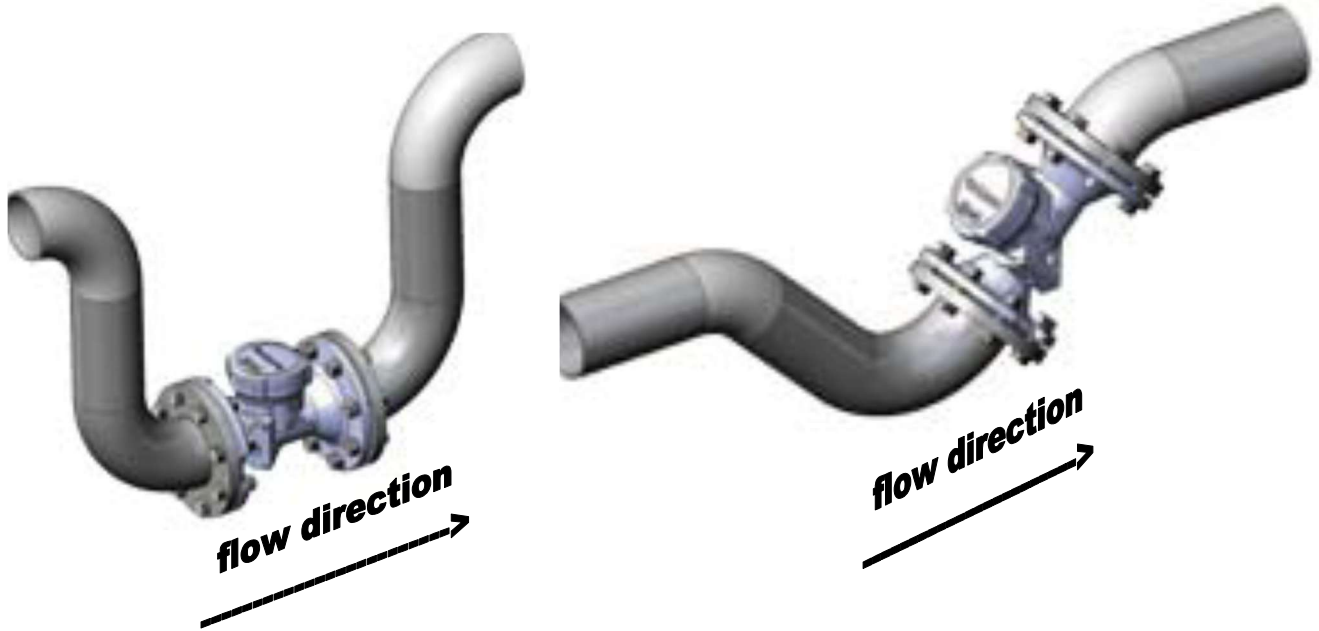

UPPER BIG BLUE NATURAL RESOURCES DISTRICT  
Approved Flow Meter List  
July 2025

**Senninger Flo-Wise Ag Rotor Meter & Senninger Flow-Wise Magmeter**

Minimum Installation Requirements:

**Jetting and Non-Jetting Flow** - Minimum installation distance is 5 pipe diameters upstream and 2 pipe diameters downstream of the flow meter in both jetting and non-jetting flow circumstances.

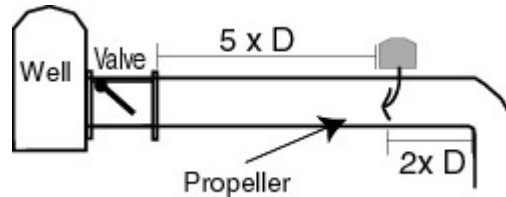

The Senninger Flo-Wise SC Ag Rotor Meter does not require straightening vanes.

**SeaMetrics - AG1000/2000-Series Irrigation Magmeter**

Minimum Installation Requirements:

**Non-jetting flow (90 degree elbow)** – The Seametrics AG 1000/2000 Series meter can be installed directly behind an elbow or well discharge. **Where available, optimal installation distance for non-jetting flow is at least 2 pipe diameters upstream and 1 pipe diameter downstream of the flow meter.**

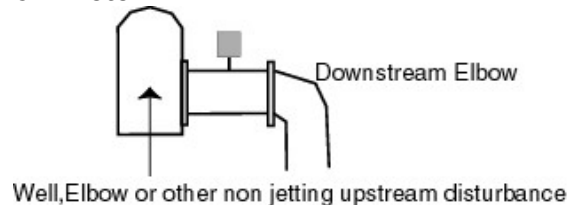

**Jetting flow** – The Seametrics AG 1000/2000 Series meter can be installed directly behind a jetting flow disturbance. **Where available, optimal installation distance for jetting flow is at least 5 pipe diameters upstream and 1 pipe diameters downstream of the flow meter.** (Examples of things that may cause jetting flow include pressure regulating valves, check valves and other in pipe restrictions).

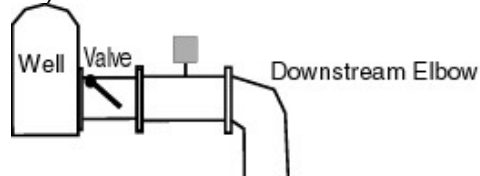

The AG1000/2000 Series Irrigation Magmeter does not require straightening vanes.

# UPPER BIG BLUE NATURAL RESOURCES DISTRICT

## Approved Flow Meter List

July 2025

### SeaMetrics – AG3000 & Valley 3000 Magmeter

Minimum Installation Requirements:

**Non-jetting flow (90 degree elbow)** – The Seametrics AG 3000 & Valley 3000 Series meter can be installed directly behind an elbow or well discharge. **Where available, optimal installation distance for non-jetting flow is at least 2 pipe diameters upstream and 1 pipe diameter downstream of the flow meter.**

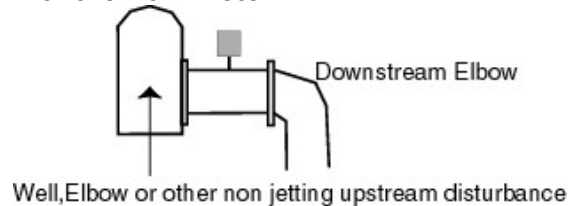

**Jetting flow** – The Seametrics AG 3000 & Valley 3000 Series meter can be installed directly behind a jetting flow disturbance. **Where available, optimal installation distance for jetting flow is at least 5 pipe diameters upstream and 1 pipe diameters downstream of the flow meter.** (Examples of things that may cause jetting flow include pressure regulating valves, check valves and other in pipe restrictions).

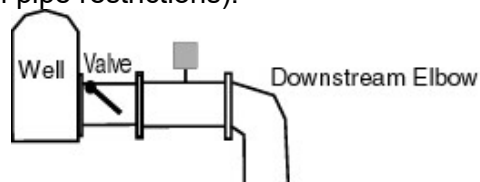

The AG1300 & Valley 3000 Series Irrigation Magmeter does not require straightening vanes.

### SeaMetrics – AG90 Insertion Flow Meter

Choose a position that will ensure a full pipe.

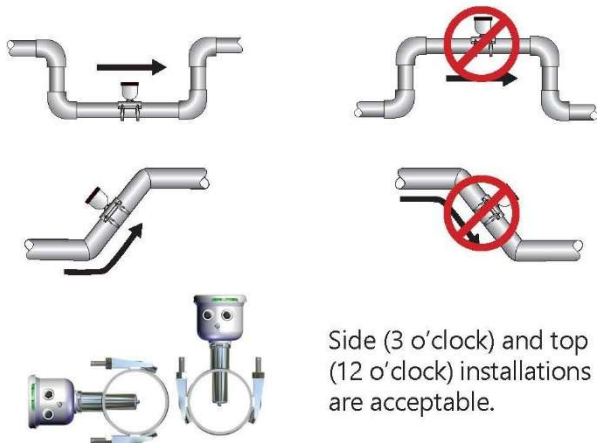

Choose a position that will minimize flow distortion.

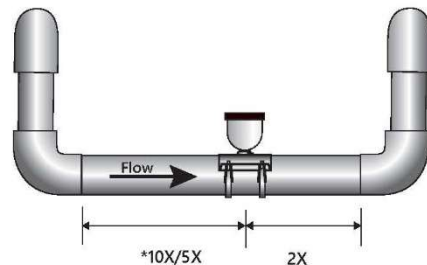

*\*Upstream straight pipe is selected during initial setup. Upstream options are 5X or 10X the diameter and are based on the amount of straight pipe available in either new or propeller meter replacement installation. Downstream straight pipe requirement is 2X the diameter. See programming setup for details.*

#### Flow Straightening Vanes/Conditioners

1. If you have the bolt-in, 3-vane style they may be removed or left in place. They do not affect performance.
2. If you have the 6-vane, bolt-in style with a cone, it should be removed.
3. For 6-vane, weld-in style installed in a spool, turn the spool 180° and reinstall with the vanes behind the meter.
4. Orifice, tube or Vortab style conditioners will not affect performance.

**UPPER BIG BLUE NATURAL RESOURCES DISTRICT**  
**Approved Flow Meter List**  
 July 2025

**Seametrics – WMP104 Plastic Bodied Magmeter (2" & 3" models)**

Minimum Installation Requirements: *Diagrams taken from document LT-65650290r1.2 20161006\_10/6/16*

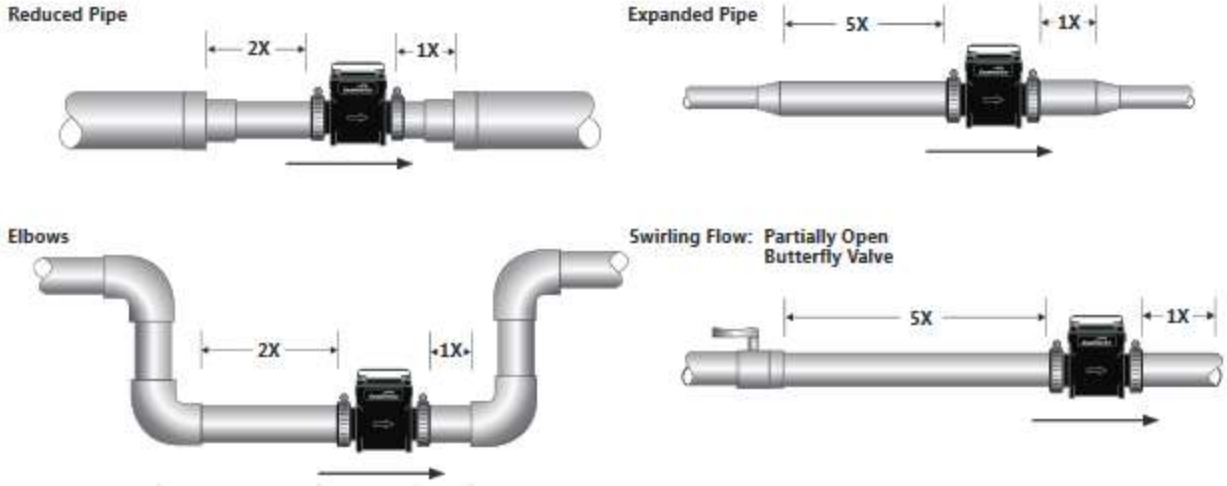

**Full Pipe Recommendations**

**Possible Problem**



*Allows air pockets to form at sensor*

**Better Installation**



*Ensures full pipe*

**Possible Problem**



*Post-valve cavitation can create air pocket*

**Better Installation**



*Keeps pipe full at sensor*

**Possible Problem**



*Air can be trapped*

**Better Installation**



*Allows air to bleed off*

**UPPER BIG BLUE NATURAL RESOURCES DISTRICT**  
**Approved Flow Meter List**  
 July 2025



**Meter Positioning**

It is important to install flowmeters so the readings are always accurate. The meters are designed to give a zero reading, should one or more electrodes become exposed. Air bubbles and sediment in the pipe can cause false readings.

It is preferred that you install the flowmeter in a pipeline location where the pipe will be full when there is flow. Orientate the flow meter in a vertical position (meter positioned on top of the pipe) as well. Never install the flowmeter with the meter horizontal to the pipeline or below the pipe. The following diagram shows proper and improper meter positioning.

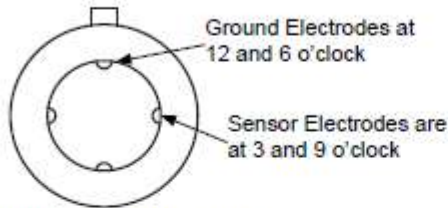

Meter/Sensor Orientation

NOTE: Meters may be clocked up to 45° if necessary

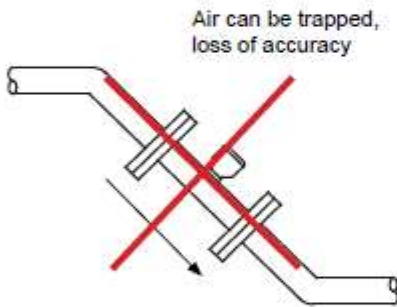

Problematic Meter Positioning

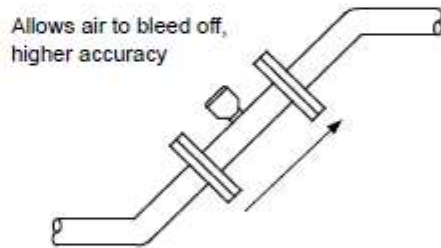

Recommended Meter Positioning

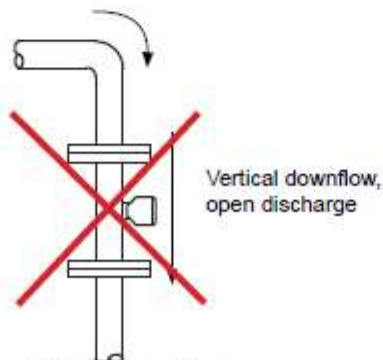

Problematic Meter Positioning

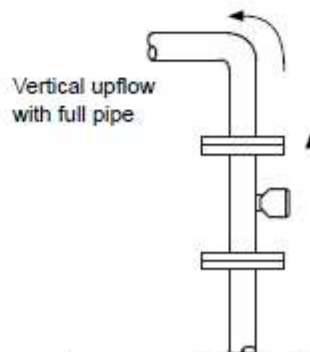

Recommended Meter Positioning

UPPER BIG BLUE NATURAL RESOURCES DISTRICT  
Approved Flow Meter List  
July 2025



### Straight Pipe Recommendations

In order to achieve optimal meter accuracy and performance, it is necessary to provide sufficient lengths of straight pipe upstream and down stream from the IM3000 Flowmeter. The following are common examples of installation conditions and recommended minimum straight pipe lengths. These serve as general guidelines and do not cover all possible conditions or any specific local regulatory requirements. If there is a question with regards to a specific installation configuration, please contact the manufacturer for further support.

#### Pipe Elbow, Valve and Pump

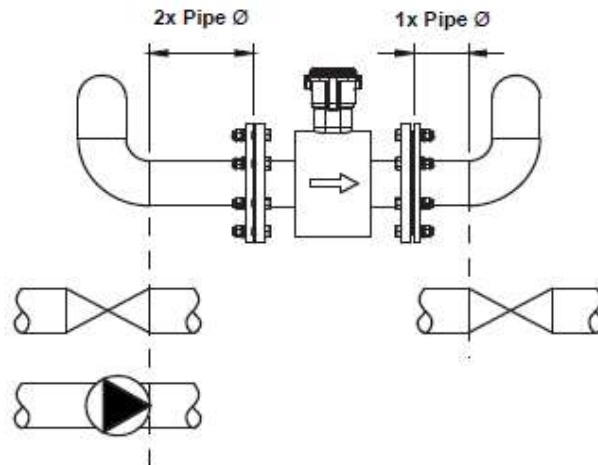

NOTE: Valve denotes a fully open butterfly or gate valve. When installed with a pump, the IM3000 should always be located downstream of the pump discharge. Installing meters upstream of a pump intake is generally not recommended.

**Updated March 20, 2018**

#### Summary:

This notice is to inform you that Lindsay has conducted thorough, controlled testing on the performance of the Growsmart IM3000 flow meter when close-coupled to 1) a 90-degree pipe elbow, 2) a vertical turbine discharge head, and 3) a swinging disc check valve. In each of these cases, the IM3000 was able to demonstrate +/-2% accuracy, despite having zero straight pipe upstream of its installation.

#### Background and Details:

Installing any make/model of electromagnetic flow meter with manufacturer recommended distances of upstream straight pipe is necessary for the meter to achieve its optimal accuracy. The IM3000 is capable of +/- 1% measurement accuracy, when installed according to the straight pipe recommendations specified by the Growsmart installation manual, which is typically 2 pipe diameters (PD) upstream of the meter.

However, in certain agricultural installations, the piping configuration does not provide sufficient straight pipe. Lindsay has conducted thorough testing on the commonly seen installations below, and determined that in each case, the meter accuracy remains within +/-2%.



Zero Distance from Pipe Elbow



Zero Distance from Turbine  
Pump Discharge



Zero Distance from Check  
Valve

UPPER BIG BLUE NATURAL RESOURCES DISTRICT  
Approved Flow Meter List  
July 2025

**Sparling BlueWater Electromagnetic Flow Meter**

Minimum Installation Requirements:

**3.2 Site Selection**

Select a pipe location that will always be full of liquid. The equipment should be located where the flowmeter will be accessible for adjustment. Provide a minimum of 18" clearance to the electronics enclosure.

The meter may be located in any position from vertical to horizontal. Flow may be in either direction through the meter. When installing in a vertical direction, however, upflow of fluid is preferred to assure a full pipe condition.

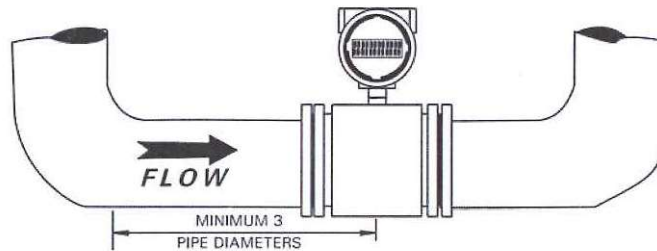

Figure 3.1

Horizontal installation requires that the sensing electrodes be positioned in the horizontal plane. See Figure 3.7.

Provide at least three pipe diameters of straight piping approach between an upstream elbow and the midpoint of the meter. More straight approach should be provided after valves or multiple elbows. Provide at least 10 diameters after expanders or laterals which are of smaller diameter than the line size.

# UPPER BIG BLUE NATURAL RESOURCES DISTRICT

## Approved Flow Meter List

July 2025

### Sparling FM31/FT194 Low Pressure Bolt-on Propeller Flow Meter

Minimum Installation Requirements:

#### 3.1 Site Selection Criteria

Choose a location that assures a pipe full of water flowing at or above minimum velocity for the meter. There should not be any enlargements, diffusers or obstructions upstream that would produce a jet or spiraling flow into the meter. 10 diameters of straight pipe upstream and 1 diameter downstream are recommended to avoid errors caused by skewed velocity profiles. See Figure 3.1

A jet caused by a partially opened valve, a centrifugal pump, or a pipe enlargement upstream from the meter can cause inaccurate registration.

Often such disturbances can be avoided by locating the meter on the suction side of the pump. The meter will register just as efficiently on a vertical or slanting pipe as on a horizontal line. The straightening vanes eliminate cork-screw effects in the flow profile. Flow conditioners may be required in installations where less than optimum conditions exist. See Figure 3.1

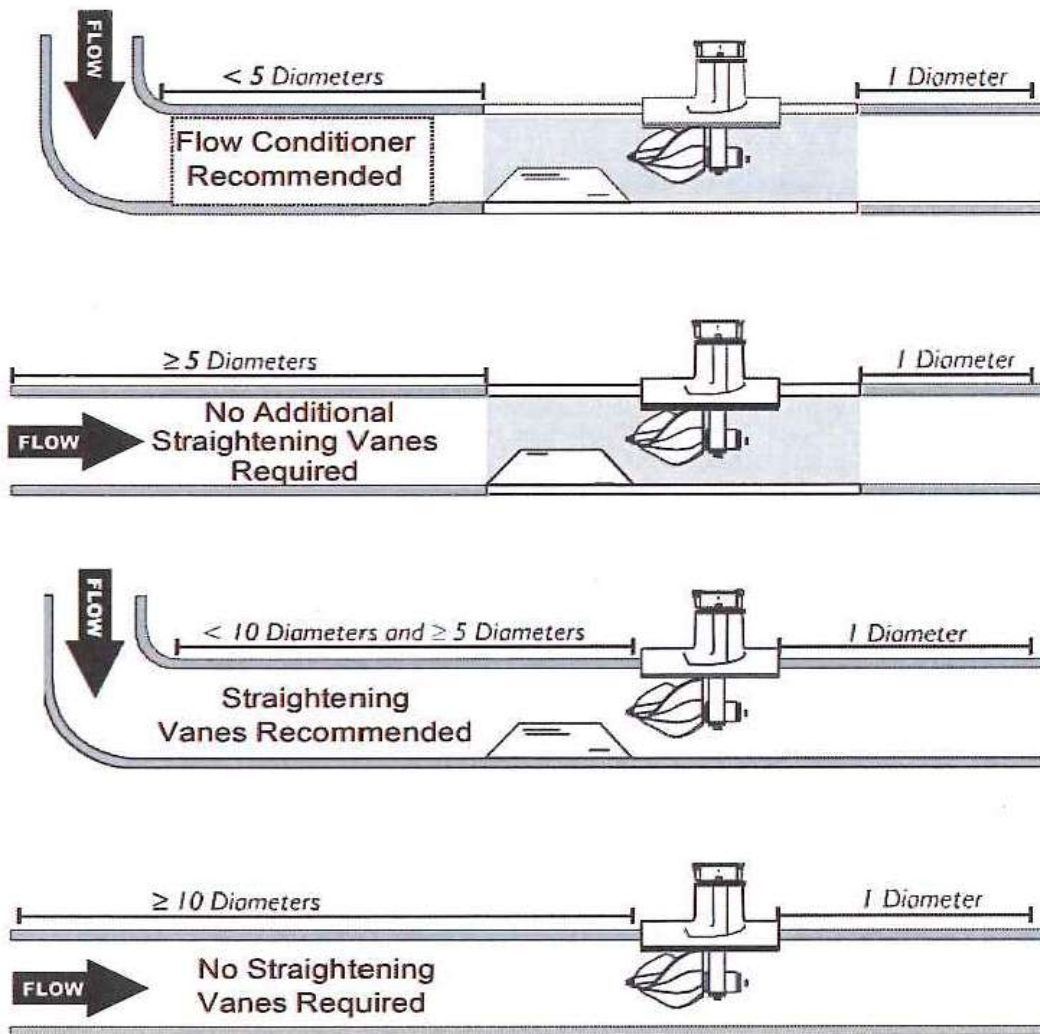

Figure 3.1  
Installation Considerations

UPPER BIG BLUE NATURAL RESOURCES DISTRICT  
Approved Flow Meter List  
July 2025

**Bermad – M10 Electromagnetic Sensor Flow Meter**

M10



## Installation with no upstream and downstream distances

The M10 internal part of the sensor, allows an optimized and accelerated flow profile which permits to install the sensor in any kind of condition; no need to have straight sections/segments of pipes upstream and downstream. This U0-D0 condition enables to have an extreme flexibility on the flow meter installation position.

## Standards reference

The M10 electromagnetic meters are marked CE and are manufactured according to the following standards:

- 2014/53/EU
- 2014/30/EU - EN 61326-1:2013 (EMC)
- 2014/65/EU
- EN IEC 60529
- OIML R49-1:2013
- European directive 2014/32/EU (MID)
- NSF

**UPPER BIG BLUE NATURAL RESOURCES DISTRICT**  
**Approved Flow Meter List**  
 July 2025

M10

## Technical features M10

FEATURES	M10	
Structure	Integral Flow meter	
DN Range	2" - 6"	
Nominal Pressure	250 PSI	
Process Connection	Victaulic OGS	
Fluid Conductivity	> 20 µS/cm	
Process Temperature Range	32 - 176 °F	
Materials in contact with water	Flow tube: Glass fibre reinforced plastic Electrodes: AISI316L	
Power supply	Battery Powered: 3.6 V Lithium Battery Mains Powered: 12Vdc (10.8 - 13.2V), max 100mA	
Consumption	0.25W-1W (Mains powered)	
Outputs	2 passive outputs (1 programmable), SSR Type (dry contact), galvanically insulated Max. load +/- 35VDC, 100 mA protected against short circuits, minimum pulse duration 5ms. RS485 2 wire /half duplex	
Communication	Modbus RTU Slave Bluetooth	
Display	LCD Segment display, with dedicated status icons, 8+6 digits	
User Interfaces	Magnetic reed Bluetooth Mobile App Euromag Link Software	
Process memory	100,000 data lines Programmable frequency 1 - 120 minutes (15 minutes factory standard)	
Metrological certificate	DIML R49-I:2013 / MID 2014/32/EU - Class 2 (if requested)	
Temperature range	Ambient: -4 - 140 °F Process: 32 - 176 °F Storage: -40 - 158 °F	
Technical units	m, m3, l, ML, ft3, gal, AC FT, AC IN	
Totalizers	5 (2 Positive, 2 Negative, 1 Net)	
Alarms and status icons	Status icons displayed and alarms recorded in the data logger	
Self diagnostic	Excitation failure Excessive ambient temperature Wet electronic board Low battery level / Mains voltage out of range Pulses overlapping	Bluetooth communication error Empty pipe Measurement error Software/memory malfunction Mains power interruption
Software for communication and programming	Bluetooth Mobile App - Mag-Net Euromag Link Software (through Bluetooth dongle, or RS485 interface)	
Data Protection	Customizable password protection EEPROM Memory with safe data storage management	

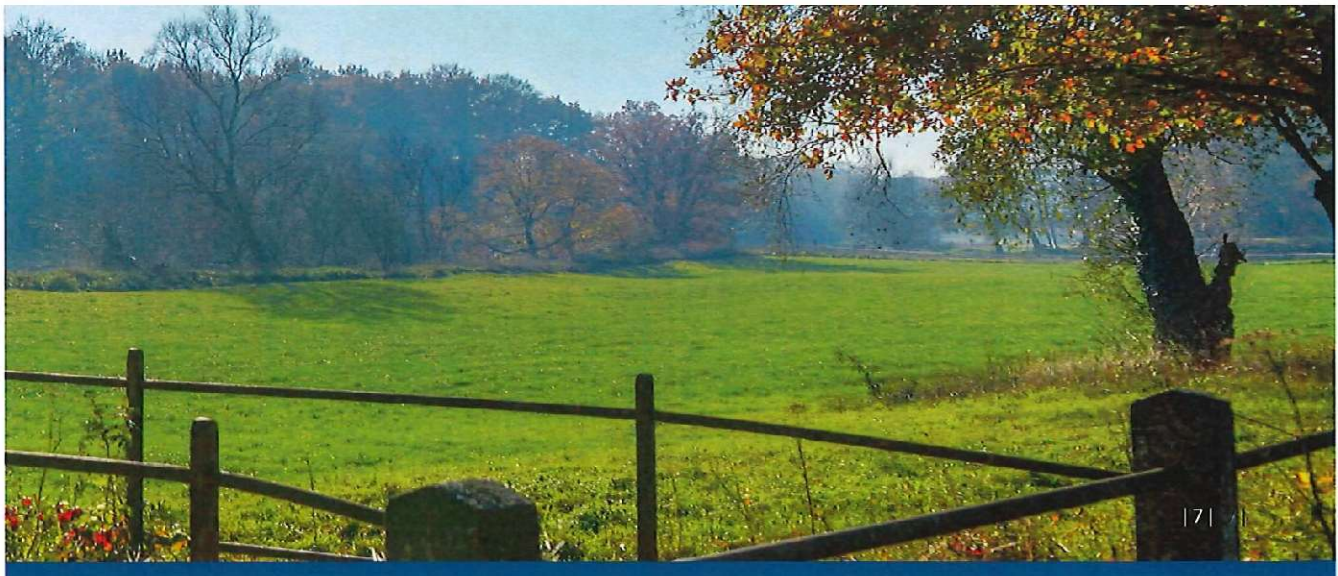

**UPPER BIG BLUE NATURAL RESOURCES DISTRICT**  
**Approved Flow Meter List**  
 July 2025

**M10**

**Overall Dimensions**

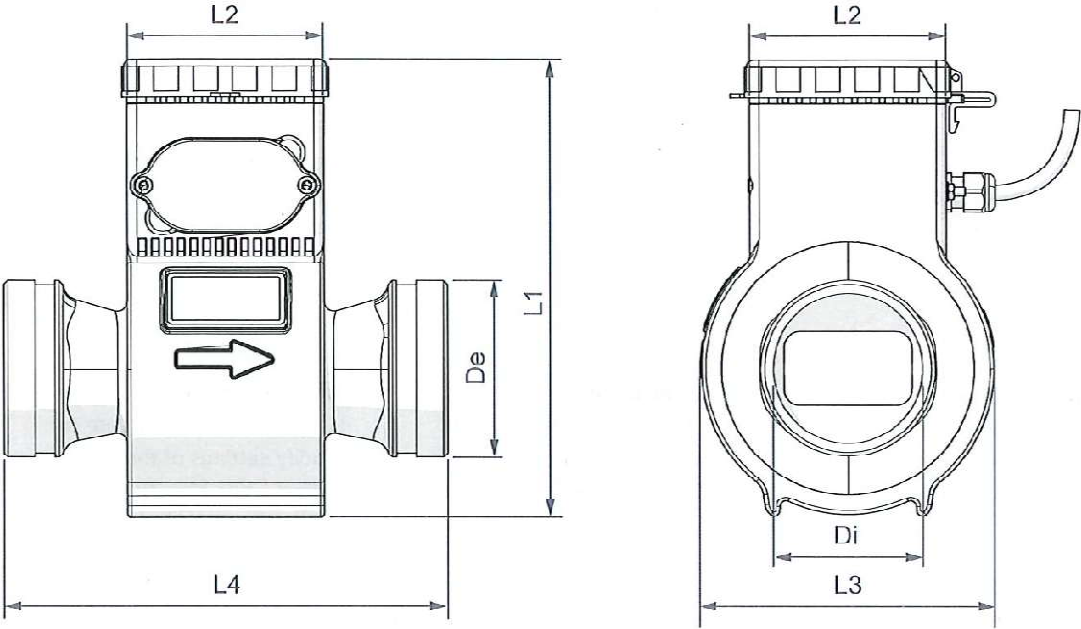

Size	De	L1	L2	L3	L4
2"	2.36	9.05	3.93	5.90	7.87
3"	3.46	9.05	3.93	5.90	8.58
4"	4.50	9.05	3.93	5.90	9.84
6"	6.62	11.8	3.93	8.26	11.8

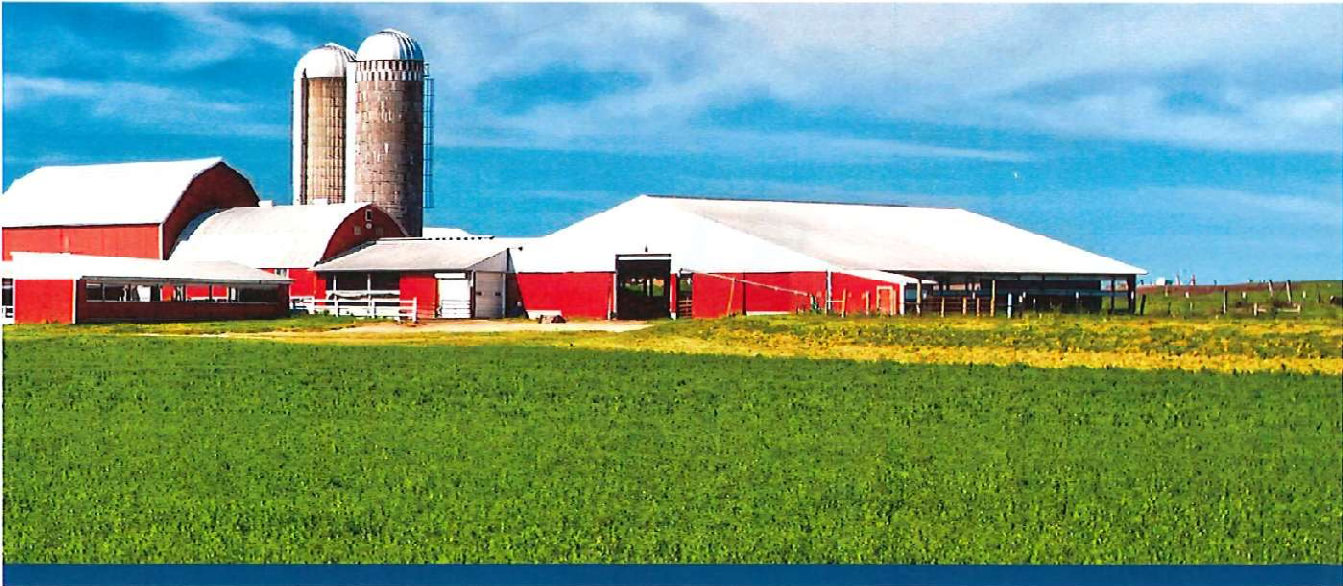

UPPER BIG BLUE NATURAL RESOURCES DISTRICT  
Approved Flow Meter List  
July 2025

## Bermad – MUT2300/MC406 Electromagnetic Flow Meter



The MUT2300 with MC406 is a battery powered electromagnetic water meter for use in district metering areas (DMA), water abstraction, and custody transfer measurement of potable water (MI-001, OIML R49), irrigation, and many other applications. Unlike other water meters, the MUT2300 is a maintenance-free meter, offering a much wider range of flow, in a compact or remote mounted version. Thanks to the optimized flow profile, the MUT2300 can be installed virtually anywhere without straight inlet or outlet runs, behind pipe bends, slide valves or a reduction in the pipe. Its measuring tube is in fact specifically designed to enable a stable measurement even at the lowest flow rates, maintaining a neglectable pressure loss in all its range. With optional pressure and temperature sensors, GSM/GPRS integrated modem and 12...24Vdc power source, the meter is the perfect solution for leak detection, and pressure management systems. The highly robust structure, allows burial installation or the use in flooded areas. A full on-site verification without process interruption can be carried out using the Field Vericator service tool.

### Applications

- District metering of potable water
- Distribution, municipal water
- Industrial waste water
- Overnight applications with very low flow rate
- Industrial process liquids, muds and concretes
- Installation in small places without straight distances
- Leak detection and monitoring
- Fiscal measures, custody transfer
- Irrigation
- Booster pump stations
- Lift stations

### Key advantages

- No moving parts
- Neglectable pressure drop
- Long lasting stability and precision
- Zero maintenance
- Extremely sturdy structure
- High chemical resilience
- Wider range of measurement

### Product's benefit

**High performances to a low cost of ownership:** Capability to read flow velocities of 0.015 m/s (MID-001 OIML R49 certified), within Class 1 accuracy

**Up to 10 years of battery life:** High-efficiency, technologically advanced battery powered converter

**U0-D0:** Zero upstream and downstream distances (MID-001 OIML R49 certified)

**No data lost:** Data automatically stored in the internal EEPROM memory. Up to 100.000 lines of active datalogging

**Information always available:** Add-on communication module GSM/GPRS automatically sends the information via SMS, e-mail or on a website portal [www.euromagdata.com](http://www.euromagdata.com) with personal ID and password. Accessible also from smart phones and tablets. Configurable FIP communication.

**Empty pipe detection:** Empty pipe electrode supplied as standard ( $\geq$  DN65). Empty pipe detection on measuring electrodes standard for all sizes

**Flow - pressure – temperature; all at the same time:** Add on modules of temperature and pressure readying make the MUT2300 with MC406 one of the most complete electromagnetic flowmeter available in the market

**Easy management, easy programming:** A software is supplied with the unit to allow users to communicate with the MC406 via IRCOM port to any pc, lap top or windows tablet.

**Certifications and compliance:** OIML R49-MID Class 1 (on request) / EX - IEC IECEx (on request and only separate version) / NSF ANSI61 (On model MUT2300US)

**Always verified:** The Euromag FIELD VERIFICATOR is available for full on-site verification, without interruption of the process

UPPER BIG BLUE NATURAL RESOURCES DISTRICT  
Approved Flow Meter List  
July 2025

MUT2300 | MC406

Features

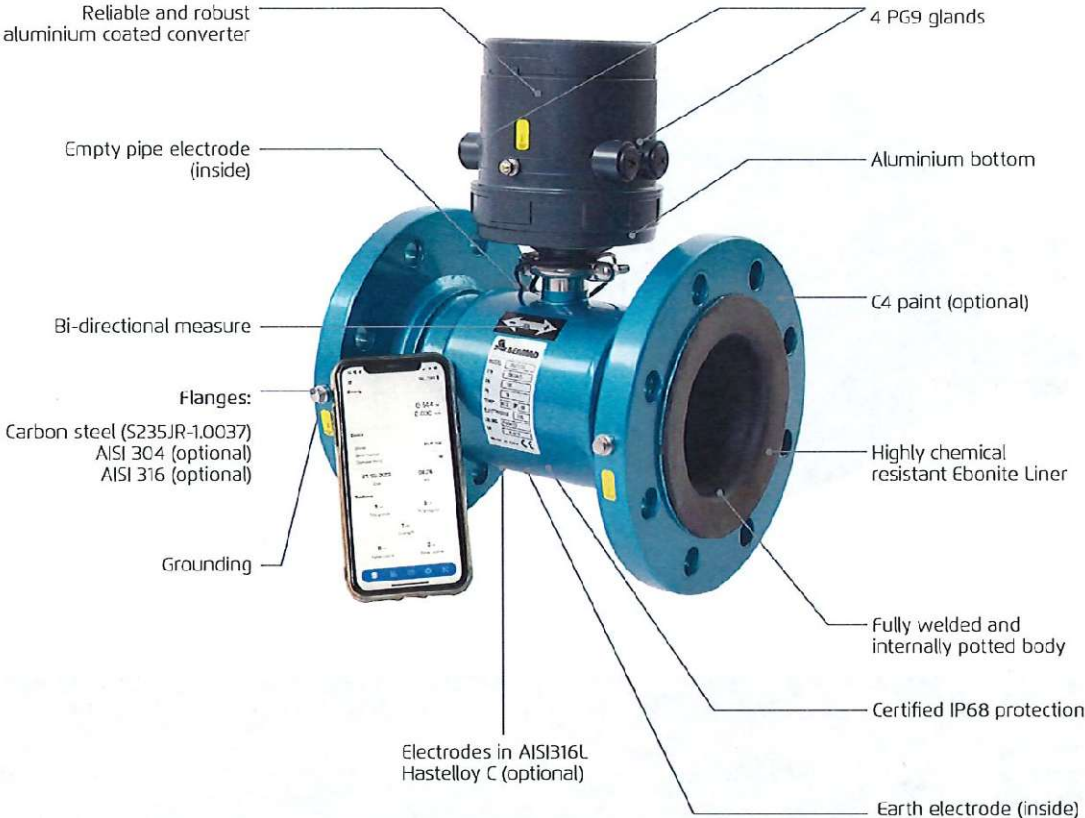

UPPER BIG BLUE NATURAL RESOURCES DISTRICT  
Approved Flow Meter List  
July 2025



Features

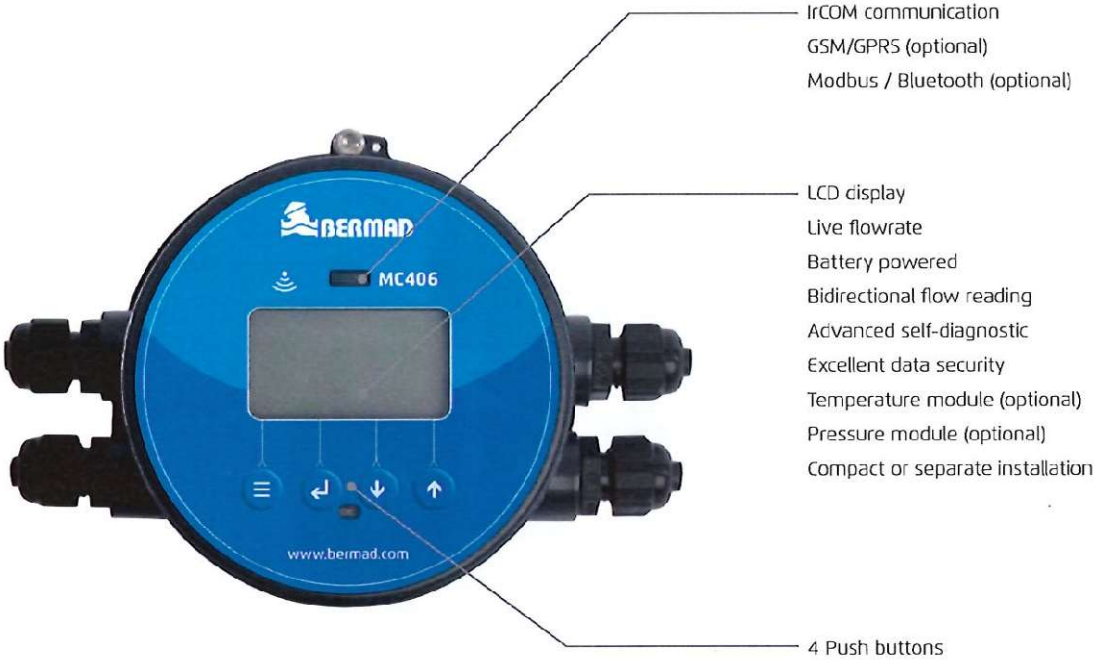

UPPER BIG BLUE NATURAL RESOURCES DISTRICT  
Approved Flow Meter List  
July 2025

The following meters are approved for *non-irrigation* applications only\*

**Elster AMCO Water evoQ4 Electromagnetic water meter**

Minimum Installation Requirements:

- The pipe must always be filled completely with the flowing fluid.

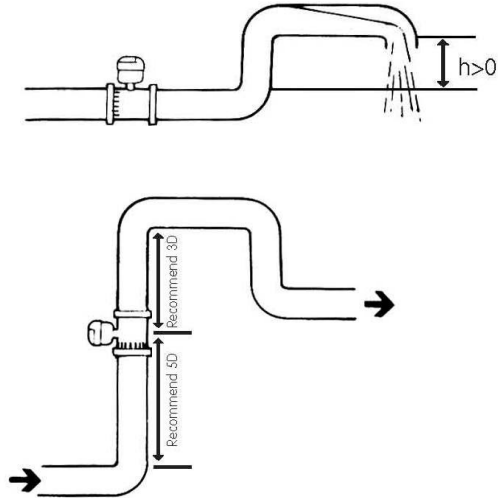

When installing the meter on vertical piping, make sure to mount it on a pipe section in which the fluid flows upwards.

## UPPER BIG BLUE NATURAL RESOURCES DISTRICT

### Approved Flow Meter List

July 2025

- A straight section of the pipe is recommended for meter installation.

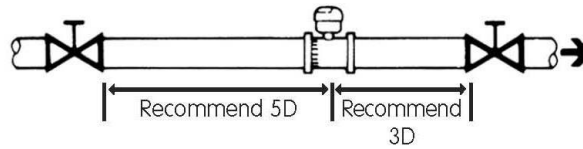

During fully open position using various valves; the meter can be fixed directly to a gate valve being fully opened.



Applicable to various control valves, such as butterfly and ball valves.

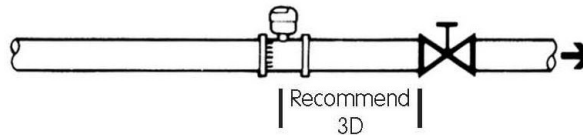

Be sure to install control valves towards the lower end of the downward flow as possible.

### Hays Turbine Meter - WP Series

Minimum Installation Requirements:

Minimum installation distance is 5 pipe diameters upstream and 3 pipe diameters downstream of the flow meter.

### Master Meter – Multi-Jet Water Meters (5/8” thru 2” sizes)

Minimum Installation Requirements:

A low pressure loss shutoff valve must be installed upstream and downstream of the meter.

The meter must be installed in horizontal plane, with the register upright, in a location accessible for reading, service and inspection.

Manufacturer design and installation instructions must be followed for these meters.

### GPI A1 Commercial Grade Meters – A100, A200 and N100

Minimum Installation Requirements:

Avoid installing the meter in electrically “noisy” environments.

Minimum installation distance for A100 and N100 (1” size) is 20 inches upstream and 5 inches downstream of the flow.

Minimum installation distance for A200(2” size) is 40 inches upstream and 10 inches downstream of the flow.

**UPPER BIG BLUE NATURAL RESOURCES DISTRICT**  
**Approved Flow Meter List**  
July 2025

**Neptune High Performance Turbine Meter**

Minimum Installation Requirements:

Installations without the Neptune strainer require a minimum installation distance of 6 pipe diameters downstream from flow disturbances.